

# S10 Rudders, Sole Pieces and Rudder Horns

(1986)  
 (Rev.1  
 1990)  
 (Corr.1  
 July  
 1999)  
 (Corr.2  
 July  
 2003)  
 (Rev.2  
 May  
 2010)  
 (Rev.3  
 Mar  
 2012)  
 (Corr.1  
 May  
 2015)  
 (Rev.4  
 Apr  
 2015)  
 (Corr.1  
 Dec  
 2015)

## S10.1 General

### 1.1 Basic assumptions

1.1.1 This UR applies to ordinary profile rudders, and to some enhanced profile rudders with special arrangements for increasing the rudder force.

1.1.2 This UR applies to rudders made of steel.

### 1.2 Design considerations

1.2.1 Effective means are to be provided for supporting the weight of the rudder without excessive bearing pressure, e.g. by a rudder carrier attached to the upper part of the rudder stock. The hull structure in way of the rudder carrier is to be suitably strengthened.

1.2.2 Suitable arrangements are to be provided to prevent the rudder from lifting.

1.2.3 In rudder trunks which are open to the sea, a seal or stuffing box is to be fitted above the deepest load waterline, to prevent water from entering the steering gear compartment and the lubricant from being washed away from the rudder carrier. If the top of the rudder trunk is below the deepest waterline, two separate stuffing boxes are to be provided.

### 1.3 Materials

1.3.1 Welded parts of rudders are to be made of approved rolled hull materials.

1.3.2 Material factor  $k$  for normal and high tensile steel plating may be taken into account when specified in each individual rule requirement. The material factor  $k$  is to be taken as defined in UR S4, unless otherwise specified.

1.3.3 Steel grade of plating materials for rudders and rudder horns are to be in accordance with UR S6.

#### Note:

1. Changes introduced in Rev.3 are to be uniformly implemented by IACS Members for ships contracted for construction on or after 1 January 2013.
2. The "contracted for construction" date means the date on which the contract to build the vessel is signed between the prospective owner and the shipbuilder. For further details regarding the date of "contract for construction", refer to IACS Procedural Requirement (PR) No. 29.
3. Changes introduced in Rev.4 are to be uniformly implemented by IACS Members for ships contracted for construction on or after 1 July 2016.

## S10 (cont)

1.3.4 Rudder stocks, pintles, coupling bolts, keys and cast parts of rudders are to be made of rolled, forged or cast carbon manganese steel in accordance with ~~unified requirements~~ UR W7, W8 and W11.

1.3.5 For rudder stocks, pintles, keys and bolts the minimum yield stress is not to be less than 200 N/mm<sup>2</sup>. The ~~following~~ requirements of this UR are based on a material's yield stress of 235 N/mm<sup>2</sup>. If material is used having a yield stress differing from 235 N/mm<sup>2</sup> the material factor k is to be determined as follows:

$$K = \left( \frac{235}{\sigma_F} \right)^e \quad \underline{k = \left( \frac{235}{\sigma_F} \right)^e}$$

with

$$e = 0.75 \text{ for } \sigma_F > 235 \text{ N/mm}^2$$

$$e = 1.00 \text{ for } \sigma_F \leq 235 \text{ N/mm}^2$$

$$\sigma_F = \text{yield stress (N/mm}^2\text{) of material used, and is not to be taken greater than } 0.7\sigma_T \text{ or } 450 \text{ N/mm}^2, \text{ whichever is the smaller value}$$

$$\sigma_T = \text{tensile strength (N/mm}^2\text{) of material used}$$

### 1.4 Welding and design details

1.4.1 Slot-welding is to be limited as far as possible. Slot welding is not to be used in areas with large in-plane stresses transversely to the slots or in way of cut-out areas of semi-spade rudders.

When slot welding is applied, the length of slots is to be minimum 75 mm with breadth of 2 t, where t is the rudder plate thickness, in mm. The distance between ends of slots is not to be more than 125 mm. The slots are to be fillet welded around the edges and filled with a suitable compound, e.g. epoxy putty. Slots are not to be filled with weld.

Continuous slot welds are to be used in lieu of slot welds. When continuous slot welding is applied, the root gap is to be between 6-10 mm. The bevel angle is to be at least 15°.

1.4.2 In way of the rudder horn recess of semi-spade rudders, the radii in the rudder plating are not to be less than 5 times the plate thickness, but in no case less than 100 mm. Welding in side plate ~~are~~ is to be avoided in or at the end of the radii. Edges of side plate and weld adjacent to radii are to be ground smooth.

1.4.3 Welds between plates and heavy pieces (solid parts in forged or cast steel or very thick plating) are to be made as full penetration welds. In way of highly stressed areas e.g. cut-out of semi-spade rudder and upper part of spade rudder, cast or welding on ribs is to be arranged. Two sided full penetration welding is normally to be arranged. Where back welding is impossible welding is to be performed against ceramic backing bars or equivalent. Steel backing bars may be used and are to be continuously welded on one side to the heavy piece.

1.4.4 Requirements for welding and design details of rudder trunks are described in S10.9.3.

## S10 (cont)

1.4.5 Requirements for welding and design details when the rudder stock is connected to the rudder by horizontal flange coupling are described in S10.6.1.4.

1.4.6 Requirements for welding and design details of rudder horns are described in S10.9.2.3.

### 1.5 Equivalence

1.5.1 The Society may accept alternatives to requirements given in this UR, provided they are deemed to be equivalent.

1.5.2 Direct analyses adopted to justify an alternative design are to take into consideration all relevant modes of failure, on a case by case basis. These failure modes may include, amongst others: yielding, fatigue, buckling and fracture. Possible damages caused by cavitation are also to be considered.

1.5.3 If deemed necessary by the Society, lab tests, or full scale tests may be requested to validate the alternative design approach.

## S10.2 Rudder force and rudder torque

### 2.1 Rudder blades without cut-outs

2.1.1 The rudder force upon which the rudder scantlings are to be based is to be determined from the following formula:

$$C_R = K_1 \cdot K_2 \cdot K_3 \cdot 132 \cdot A \cdot V^2 \cdot K_{th} \quad [N]$$

Where:

$C_R$  = rudder force [N];

$A$  = area of rudder blade [m<sup>2</sup>];

$V$  = maximum service speed (knots) with the ship on summer load waterline. When the speed is less than 10 knots,  $V$  is to be replaced by the expression:

$$V_{min} = (V + 20) / 3$$

For the astern condition the maximum astern speed is to be used, however, in no case less than:

$$V_{astern} = 0.5 V$$

$K_1$  = factor depending on the aspect ratio  $\lambda$  of the rudder area;

$K_1$  =  $(\lambda + 2) / 3$ , with  $\lambda$  not to be taken greater than 2;

$\lambda$  =  $b^2 / A_t$ ;

$b$  = mean height of the rudder area [m]. Mean breadth and mean height of rudder are calculated according to the coordinate system in Fig. 1;

$A_t$  = sum of rudder blade area  $A$  and area of rudder post or rudder horn, if any, within the height  $b$  [m<sup>2</sup>];

# S10

(cont)

$K_2$  = coefficient depending on the type of the rudder and the rudder profile according to Table 1;

$K_3$  = 0.8 for rudders outside the propeller jet;  
 = 1.15 for rudders behind a fixed propeller nozzle;  
 = 1.0 otherwise;

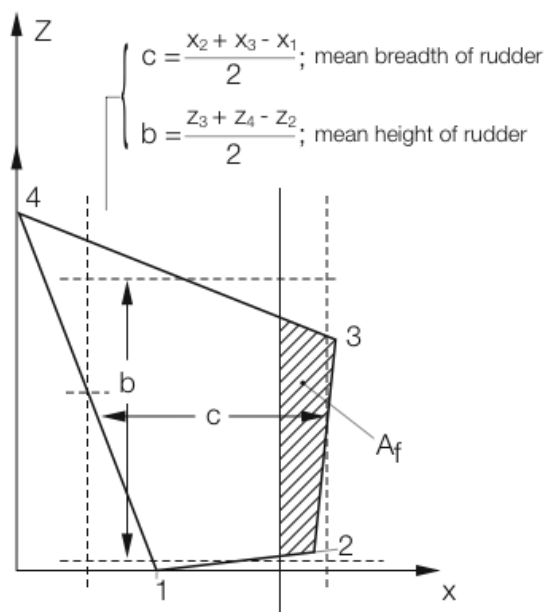

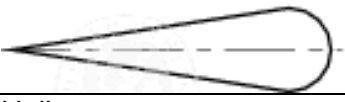



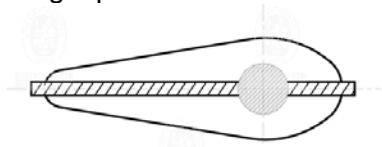

Figure 1

Profile Type	$K_2$	
	Ahead condition	Astern condition
NACA-00 series Göttingen 	1.10	0.80
Flat side 	1.10	0.90
Hollow 	1.35	0.90
High lift rudders 	1.70	to be specially considered; if not known: 1.30
Fish tail 	1.40	0.80

**S10**  
 (cont)

Single plate 	1.00	1.00
Mixed profiles (e.g. HSVA)	1.21	0.90

**Table 1**

2.1.2 The rudder torque is to be calculated for both the ahead and astern condition according to the formula:

$$Q_R = C_R r \quad [\text{Nm}]$$

$$r = c (\alpha - k_1) \quad [\text{m}]$$

$c$  = mean breadth of rudder area [m], see Fig. 1

$\alpha$  = 0.33 for ahead condition

$\alpha$  = 0.66 for astern condition

$$k_1 = A_f / A$$

$A_f$  = portion of the rudder blade area situated ahead of the centre line of the rudder stock

$$r_{\min} = 0.1c \quad [\text{m}] \quad \text{for ahead condition}$$

## 2.2 Rudder blades with cut-outs (semi-spade rudders)

The total rudder force  $C_R$  is to be calculated according to S10.2.1.1. The pressure distribution over the rudder area, upon which the determination of rudder torque and rudder blade strength is to be based, is to be derived as follows:

The rudder area may be divided into two rectangular or trapezoidal parts with areas  $A_1$  and  $A_2$ , so that  $A = A_1 + A_2$  (see Figure 2).

# S10

(cont)

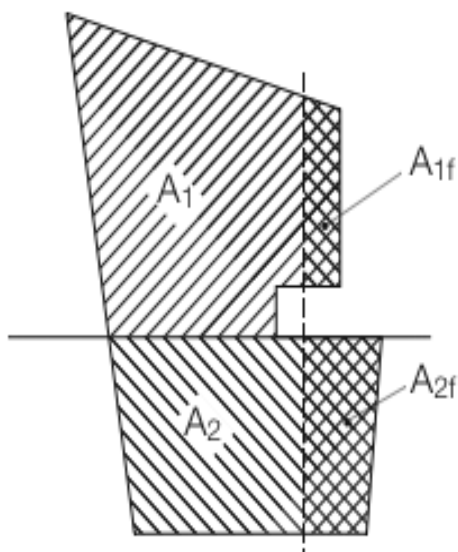

**Figure 2**

The levers  $r_1$  and  $r_2$  are to be determined as follows:

$$r_1 = c_1 (\alpha - k_1) \quad [\text{m}]$$

$$r_2 = c_2 (\alpha - k_2) \quad [\text{m}]$$

$c_1, c_2$  = mean breadth of partial areas  $A_1, A_2$  determined, where applicable, in accordance with Figure 1 Fig.1 in S10.2.1.4

$$k_1 = A_{1f} / A_1,$$

$$k_2 = A_{2f} / A_2,$$

$A_{1f}$  = portion of  $A_1$  situated ahead of the centre line of the rudder stock

$A_{2f}$  = portion of  $A_2$  situated ahead of the centre line of the rudder stock

$\alpha$  = 0.33 for ahead condition

$\alpha$  = 0.66 for astern condition

For parts of a rudder behind a fixed structure such as the rudder horn:

$\alpha$  = 0.25 for ahead condition

$\alpha$  = 0.55 for astern condition

## S10 (cont)

The resulting force of each part may be taken as:

$$C_{R1} = C_R \frac{A_1}{A} \quad [\text{N}]$$

$$C_{R2} = C_R \frac{A_2}{A} \quad [\text{N}]$$

The resulting torque of each part may be taken as:

$$Q_{R1} = C_{R1} r_1 \quad [\text{Nm}]$$

$$Q_{R2} = C_{R2} r_2 \quad [\text{Nm}]$$

The total rudder torque is to be calculated for both the ahead and astern condition according to the formula:

$$Q_R = Q_{R1} + Q_{R2} \quad [\text{Nm}]$$

For ahead condition  $Q_R$  is not to be taken less than:

$$Q_{R\min} = 0.1 C_R \frac{A_1 c_1 + A_2 c_2}{A}$$

### S10.3 Rudder strength calculation

**4.23.1** The rudder force and resulting rudder torque as given in S10.2 causes bending moments and shear forces in the rudder body, bending moments and torques in the rudder stock, supporting forces in pintle bearings and rudder stock bearings and bending moments, shear forces and torques in rudder horns and heel pieces. The rudder body is to be stiffened by horizontal and vertical webs enabling it to act as a bending girder.

**4.23.2** The bending moments, shear forces and torques as well as the reaction forces are to be determined by a direct calculation or by an approximate simplified method considered appropriate by each individual society. For rudders supported by sole pieces or rudder horns these structures are to be included in the calculation model in order to account for the elastic support of the rudder body. Guidelines for calculation of bending moment and shear force distribution are given in an annex to this UR.

### S10.4 Rudder stock scantlings

**4.1** The rudder stock diameter required for the transmission of the rudder torque is to be dimensioned such that the torsional stress ~~will~~ is not exceeding the following value:

$$\tau_T = 68 / K \quad [\text{N/mm}^2]$$

The rudder stock diameter for the transmission of the rudder torque is therefore not to be less than:

$$d_t = 4.2 \sqrt[3]{Q_R K} \quad d_t = 4.2 \sqrt[3]{Q_R k} \quad [\text{mm}]$$

$Q_R$  = total rudder torque [Nm] as calculated in S10.2.1.2 and/or S10.2.2.

## S10

(cont)

k = material factor for the rudder stock as given in S10.1.3.5

#### 4.14.2 Rudder stock scantlings due to combined loads

If the rudder stock is subjected to combined torque and bending, the equivalent stress in the rudder stock is not to exceed  $118 / k$  N/mm<sup>2</sup>.

k = material factor for the rudder stock as given in S10.1.3.5

The equivalent stress is to be determined by the formula:

$$\sigma_c = \sqrt{\sigma_b^2 + 3\tau_t^2} \quad [\text{N/mm}^2]$$

Bending stress:  $\sigma_b = 10.2 M / d_c^3$   $\sigma_b = 10.2 \times 10^3 M / d_c^3$  [N/mm<sup>2</sup>]

Torsional stress:  $\tau_t = 5.1 Q_R / d_c^3$   $\tau_t = 5.1 \times 10^3 Q_R / d_c^3$  [N/mm<sup>2</sup>]

The rudder stock diameter is therefore not to be less than:

$$d_c = d_t \sqrt[6]{1 + 4/3 [M/Q_R]^2} \quad [\text{mm}]$$

M = bending moment [Nm] at the station of the rudder stock considered

**4.3** Before significant reductions in rudder stock diameter due to the application of steels with yield stresses exceeding 235 N/mm<sup>2</sup> are granted, the Society may require the evaluation of the rudder stock deformations. Large deformations of the rudder stock are to be avoided in order to avoid excessive edge pressures in way of bearings.

### S10.5 Rudder blade

#### 5.1 Permissible stresses

The section modulus and the web area of a horizontal section of the rudder blade are to be such that the following stresses will not be exceeded:

a) In general

- |  |                           |
|--|---------------------------|
| (i) bending stress $\sigma_b$                                    | $110/k$ N/mm <sup>2</sup> |
| (ii) shear stress $\tau$   | $50/k$ N/mm <sup>2</sup>  |
| (iii) equivalent stress $\sigma_e = \sqrt{\sigma_b^2 + 3\tau^2}$ | $120/k$ N/mm <sup>2</sup> |

k = material factor for the rudder stock plating as given in S10.1.3.2

b) In way of the recess for the rudder plating horn pintle on semi-spade rudders

- |  |                       |
|--|-----------------------|
| (i) bending stress $\sigma_b$                                    | 75 N/mm <sup>2</sup>  |
| (ii) shear stress $\tau$   | 50 N/mm <sup>2</sup>  |
| (iii) equivalent stress $\sigma_e = \sqrt{\sigma_b^2 + 3\tau^2}$ | 100 N/mm <sup>2</sup> |

Note: The stresses in b) apply equally to high tensile and ordinary steels.



**S10**

(cont)

**5.2 Rudder plating**

The thickness of the rudder side, top and bottom plating is not to be less than:

$$t = 5.5s\beta\sqrt{d + C_R 10^{-4}/A} + 2.5 \quad t = 5.5s\beta\sqrt{k\sqrt{d + C_R 10^{-4}/A} + 2.5} \quad [\text{mm}]$$

$d$  = summer loadline draught [m] of the ship;

$C_R$  = rudder force [N] according to S10.2.1.1;

$A$  = rudder area [m<sup>2</sup>];

$$\beta = \sqrt{1.1 - 0.5[s/b]^2}; \quad \text{max. 1.00 if } b/s \geq 2.5$$

$s$  = smallest unsupported width of plating in [m];

$b$  = greatest unsupported width of plating in [m].

$k$  = material factor for the rudder plating stock as given in S10.1.3.2

The thickness of the nose plates may be increased to the discretion of each Society. The thickness of web plates is not to be less than the greater of 70% of the rudder side plating thickness and 8 mm.

The rudder plating in way of the solid part is to be of increased thickness per S10.5.3.4.

**5.3 Connections of rudder blade structure with solid parts**

5.3.1 Solid parts in forged or cast steel, which house the rudder stock or the pintle, are normally to be provided with protrusions.

These protrusions are not required when the web plate thickness is less than:

- 10 mm for web plates welded to the solid part on which the lower pintle of a semi-spade rudder is housed and for vertical web plates welded to the solid part of the rudder stock coupling of spade rudders.
- 20 mm for other web plates.

5.3.2 The solid parts are in general to be connected to the rudder structure by means of two horizontal web plates and two vertical web plates.

5.3.3 Minimum section modulus of the connection with the rudder stock housing.

The section modulus of the cross-section of the structure of the rudder blade, in cm<sup>3</sup>, formed by vertical web plates and rudder plating, which is connected with the solid part where the rudder stock is housed is to be not less than:

$$w_s = c_s d_c^3 \left( \frac{H_E - H_x}{H_E} \right) \frac{k}{k_s} 10^{-4} \quad [\text{cm}^3]$$

# S10

(cont)

where:

$\epsilon_s C_s$  = coefficient, to be taken equal to:

= 1.0 if there is no opening in the rudder plating or if such openings are closed by a full penetration welded plate

= 1.5 if there is an opening in the considered cross-section of the rudder

$d_c$  = rudder stock diameter, in [mm]

$H_E$  = vertical distance between the lower edge of the rudder blade and the upper edge of the solid part, in [m]

$H_x$  = vertical distance between the considered cross-section and the upper edge of the solid part, in [m]

$k$  = material factor for the rudder blade plating as given in S10.1.3.2.

$k_s$  = material factor for the rudder stock as given in S10.1.3.5.

The actual section modulus of the cross-section of the structure of the rudder blade is to be calculated with respect to the symmetrical axis of the rudder.

The breadth of the rudder plating, in m, to be considered for the calculation of section modulus is to be not greater than:

$$b = s_v + 2 H_x / 3 \quad [m]$$

where:

$s_v$  = spacing between the two vertical webs, in [m] (see Figure 3)

Where openings for access to the rudder stock nut are not closed by a full penetration welded plate, they are to be deducted.

# S10

(cont)

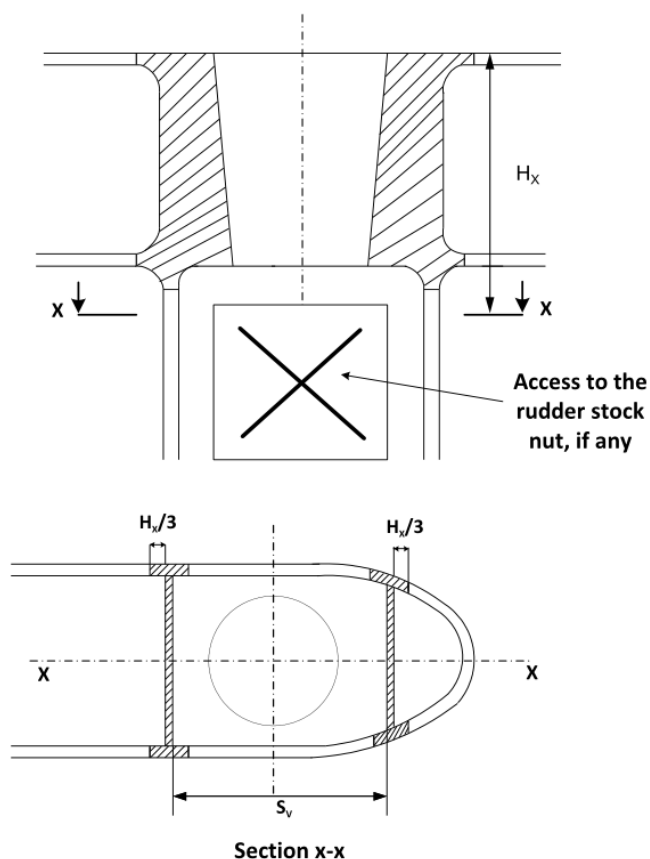

**Figure 3 Cross-section of the connection between rudder blade structure and rudder stock housing**

5.3.4 The thickness of the horizontal web plates connected to the solid parts, in mm, as well as that of the rudder blade plating between these webs, is to be not less than the greater of the following values:

$$t_H = 1.2 t \quad [\text{mm}]$$

$$t_H = 0.045 d_s S^2 / s_H H \quad [\text{mm}]$$

where:

$t$  = defined in S10.5.2

$d_s$  = diameter, in [mm], to be taken equal to:

=  $d_c$ , as per S10.4.2, for the solid part housing the rudder stock

=  $d_p$ , as per S10.7.1, for the solid part housing the pintle

$d_r$  = rudder stock diameter, in [mm]

$d_a$  = pintle diameter, in [mm]

$s_H$  = spacing between the two horizontal web plates, in [mm]

# S10

(cont)

The increased thickness of the horizontal webs is to extend fore and aft of the solid part at least to the next vertical web.

5.3.5 The thickness of the vertical web plates welded to the solid part where the rudder stock is housed as well as the thickness of the rudder side plating under this solid part is to be not less than the values obtained, in mm, from Table 2.

Type of rudder	Thickness of vertical web plates, in mm		Thickness of rudder plating, in mm	
	Rudder blade without opening	Rudder blade with opening	Rudder blade without opening	Area with opening
Rudder supported by sole piece	1.2 t	1.6 t	1.2 t	1.4 t
Semi-spade and spade rudders	1.4 t	2.0 t	1.3 t	1.6 t

t = thickness of the rudder plating, in mm, as defined in S10.5.2

**Table 2 Thickness of side plating and vertical web plates**

The increased thickness is to extend below the solid piece at least to the next horizontal web.

## 5.4 Single plate rudders

### 5.4.1 Mainpiece diameter

The mainpiece diameter is calculated according to S10.4.1 and S10.4.2 respectively. For spade rudders the lower third may taper down to 0.75 times stock diameter.

### 5.4.2 Blade thickness

The blade thickness is not to be less than:

$$t_b = 1.5sV + 2.5 \quad t_b = 1.5sV\sqrt{k} + 2.5 \quad [\text{mm}]$$

where:

s = spacing of stiffening arms in [m], not to exceed 1 m;

V = speed in knots, see S10.2.1.1.

k = material factor for the rudder plating as given in S10.1.3.2

### 5.4.3 Arms

The thickness of the arms is not to be less than the blade thickness

$$t_a = t_b \quad [\text{mm}]$$

The section modulus is not to be less than:

# S10

(cont)

$Z_a = 0.5 s C_1^2 V^2 k$  [cm<sup>3</sup>];

$C_1$  = horizontal distance from the aft edge of the rudder to the centreline of the rudder stock, in metres

$k$  = material factor as given in S10.1.3.2 or S10.1.3.5 respectively

## S10.6 Rudder stock couplings

### 6.1 Horizontal flange couplings

6.1.1 The diameter of the coupling bolts is not to be less than:

$$d_b = 0.62 \sqrt{d^3 K_b / n e_m K_s} \quad d_b = 0.62 \sqrt{d^3 k_b / n e_m k_s} \quad [\text{mm}]$$

$d$  = stock diameter, taken equal to the greater of the diameters  $d_t$  or  $d_c$  according to S10.4.1 and S10.4.2 [mm];

$n$  = total number of bolts, which is not to be less than 6;

$e_m$  = mean distance [mm] of the bolt axes from the centre of the bolt system;

$K_s$  = material factor for the stock as given in S10.1.3.5;

$K_b$  = material factor for the bolts as given in S10.1.3.5.

6.1.2 The thickness of the coupling flanges, in mm, is not to be less than the greater of the following formulae:

$$t_f = d_b \sqrt{K_f / K_b}$$

$$t_f = d_b \sqrt{k_f / k_b}$$

$$t_f = 0.9 d_b$$

$K_f$  = material factor for flange as given in S10.1.3.5;

$K_b$  = material factor for the bolts as given in S10.1.3.5;

$d_b$  = bolt diameter, in mm, calculated for a number of bolts not exceeding 8.

6.1.3 The width of material between the perimeter of the bolt holes and the perimeter of the flange is not to be less than  $0.67 d_b$ .

6.1.4 The welded joint between the rudder stock and the flange is to be made in accordance with Figure 4 or equivalent.

# S10

(cont)

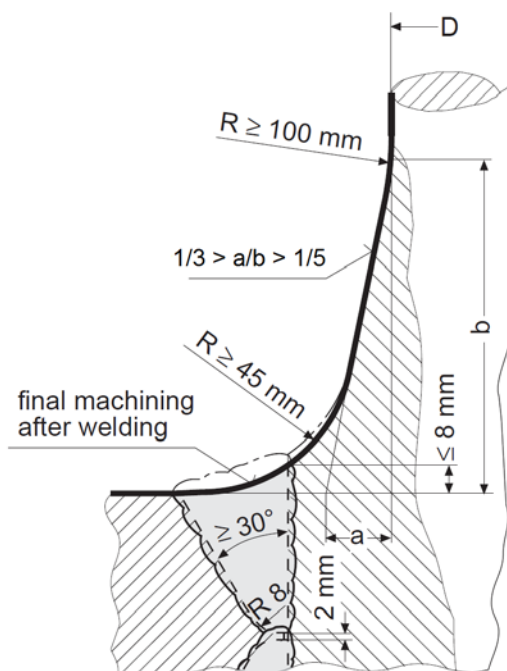

**Figure 4 Welded joint between rudder stock and coupling flange**

6.1.5 Coupling bolts are to be fitted bolts and their nuts are to be locked effectively.

## 6.2 Vertical flange couplings

6.2.1 The diameter of the coupling bolts, in mm, is not to be less than:

$$d_b = 0.81d / \sqrt{n} \times \sqrt{k_b/k_s}$$

where:

d = stock diameter [mm] in way of coupling flange;

n = total number of bolts, which is not to be less than 8;

$k_b$  = material factor for bolts as given in S10.1.3.5

$k_s$  = material factor for stock as given in S10.1.3.5

6.2.2 The first moment of area of the bolts about the centre of the coupling, m, is to be not less than:

$$m = 0.00043 e_3 d^3 \quad [\text{cm}^3]$$

6.2.3 The thickness of the coupling flanges is to be not less than the bolt diameter, and the width of the flange material between the perimeter of the bolt holes and the perimeter of the flange is to be not less than  $0.67 d_b$ .

6.2.4 Coupling bolts are to be fitted bolts and their nuts are to be locked effectively.

## S10 6.3 Cone couplings with key

(cont)

### 6.3.1 Tapering and coupling length

Cone couplings without hydraulic arrangements for mounting and dismounting the coupling should have a taper  $c$  on diameter of 1:8 - 1:12,

where:

$$c = (d_o - d_u) / \ell \quad (\text{see Figure 5})$$

The cone coupling is to be secured by a slugging nut. The nut is to be secured, e.g. by a securing plate.

The cone shapes are to fit exactly. The coupling length  $\ell$  is to be, in general, not less than  $1.5d_o$ .

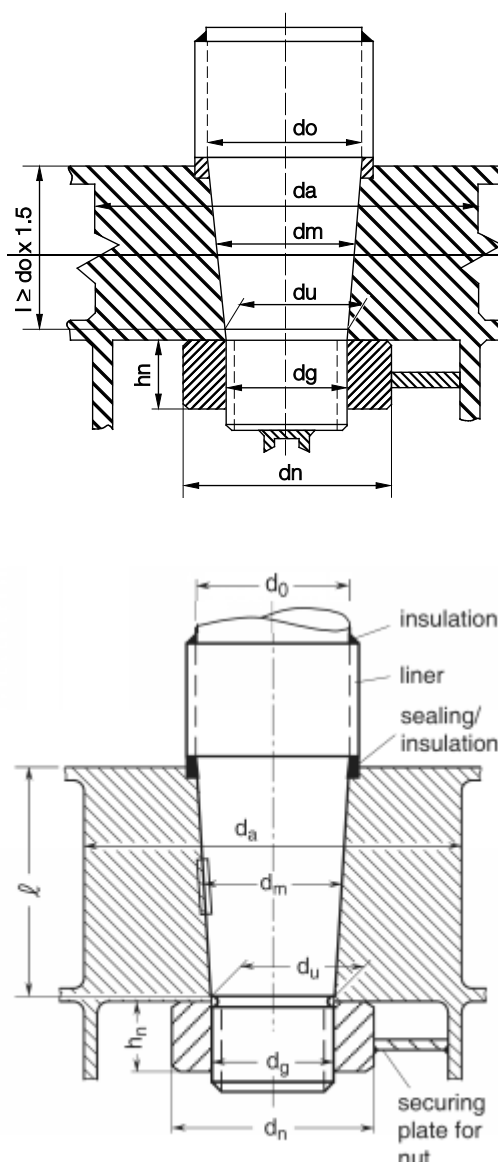

Figure 5 Cone coupling with key

# S10

(cont)

## 6.3.2 Dimensions of key

For couplings between stock and rudder a key is to be provided, the shear area of which, in  $\text{cm}^2$ , is not to be less than:

$$a_s = \frac{17.55Q_F}{d_k R_{eH1}} \quad a_s = \frac{17.55Q_F}{d_k \sigma_{F1}}$$

where:

$Q_F$  = design yield moment of rudder stock, in Nm

$$Q_F = 0.02664 \frac{d_t^3}{k}$$

Where the actual diameter  $d_{ta}$  is greater than the calculated diameter  $d_t$ , the diameter  $d_{ta}$  is to be used. However,  $d_{ta}$  applied to the above formula need not be taken greater than 1.145  $d_t$ .

$d_t$  = stock diameter, in mm, according to S10.4.1.

$k$  = material factor for stock as given in S10.1.3.5

$d_k$  = mean diameter of the conical part of the rudder stock, in mm, at the key

$\sigma_{F1}$  = minimum yield stress of the key material, in  $\text{N/mm}^2$

The effective surface area, in  $\text{cm}^2$ , of the key (without rounded edges) between key and rudder stock or cone coupling is not to be less than:

$$a_k = \frac{5Q_F}{d_k \sigma_{F2}}$$

where:

$\sigma_{F2}$  = minimum yield stress of the key, stock or coupling material, in  $\text{N/mm}^2$ , whichever is less.

## 6.3.3 The dimensions of the slugging nut are to be as follows (see Figure 5):

external thread diameter:  $d_g \geq 0.65 d_o$

height:  $h_n \geq 0.6 d_g$

outer diameter:  $d_n \geq 1.2 d_u$ , or  $1.5 d_g$

whichever is the greater.



## S10 (cont)

### 6.3.4 Push up

It is to be proved that 50% of the design yield moment is solely transmitted by friction in the cone couplings. This can be done by calculating the required push-up pressure and push-up length according to S10.6.4.2 and S10.6.4.3 for a torsional moment  $Q'_F = 0.5Q_F$ .

6.3.5 Notwithstanding the requirements in S10.6.3.2 and S10.6.3.4, where a key is fitted to the coupling between stock and rudder and it is considered that the entire rudder torque is transmitted by the key at the couplings, the scantlings of the key as well as the push-up force and push-up length are to be at the discretion of the Society.

## 6.4 Cone couplings with special arrangements for mounting and dismounting the couplings

6.4.1 Where the stock diameter exceeds 200 mm, the press fit is recommended to be effected by a hydraulic pressure connection. In such cases the cone is to be more slender,  $c \approx 1:12$  to  $\approx 1:20$ .

In case of hydraulic pressure connections the nut is to be effectively secured against the rudder stock or the pintle.

For the safe transmission of the torsional moment by the coupling between rudder stock and rudder body the push-up pressure and the push-up length are to be determined according to S10.6.4.2 and S10.6.4.3 respectively.

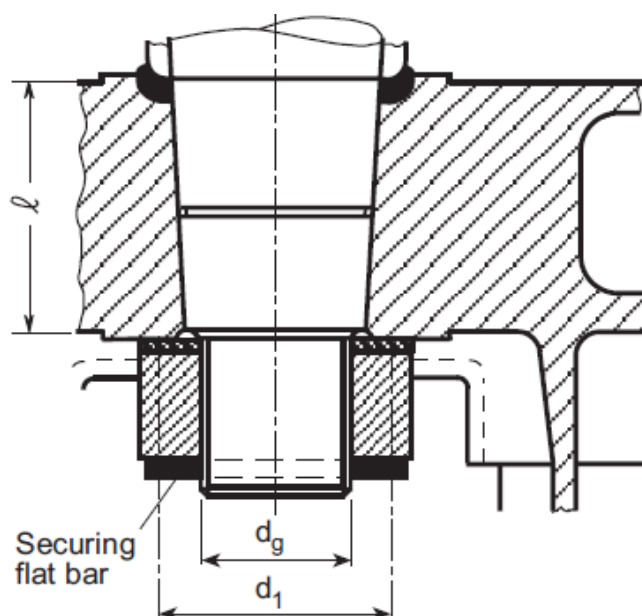

**Figure 6 Cone coupling without key**

### 6.4.2 Push-up pressure

The push-up pressure is not to be less than the greater of the two following values:

$$p_{req1} = \frac{2Q_F}{d_m^2 \ell \pi \mu_0} 10^3 \quad [\text{N/mm}^2]$$

# S10

(cont)

$$p_{req2} = \frac{6M_b}{\ell^2 d_m} 10^3 \quad [\text{N/mm}^2]$$

where:

$Q_F$  = design yield moment of rudder stock, as defined in S10.6.3.2, in [Nm]

$d_m$  = mean cone diameter in [mm], see Figure 5

$\ell$  = cone length in [mm]

$\mu_0$  = frictional coefficient, equal to 0.15

$M_b$  = bending moment in the cone coupling (e.g. in case of spade rudders), in [Nm]

It has to be proved by the designer that the push-up pressure does not exceed the permissible surface pressure in the cone. The permissible surface pressure, in N/mm<sup>2</sup>, is to be determined by the following formula:

$$p_{perm} = \frac{0.8R_{eH}(1-\alpha^2)}{\sqrt{3+\alpha^4}} \quad [\text{N/mm}^2]$$

where:

$R_{eH}$  = minimum yield stress of the material of the gudgeon in [N/mm<sup>2</sup>]

$\alpha$  =  $d_m / d_a$

$d_m$  = diameter, in [mm], see Figure 5

$d_a$  = outer diameter of the gudgeon to be not less than 1.5  $d_m$ , in [mm], see Figure 5

## 6.4.3 Push-up length

The push-up length  $\Delta\ell$ , in mm,  $\Delta\ell$  is to comply with the following formula:

$$\Delta\ell_1 \leq \Delta\ell \leq \Delta\ell_2$$

where:

$$\Delta\ell_1 = \frac{p_{req} d_m}{E \left( \frac{1-\alpha^2}{2} \right) c} + \frac{0.8R_{tm}}{c} \quad [\text{mm}]$$

$$\Delta\ell_2 = \frac{1.6R_{eH} d_m}{Ec\sqrt{3+\alpha^4}} + \frac{0.8R_{tm}}{c} \quad [\text{mm}]$$

$R_{tm}$  = mean roughness, in [mm] taken equal to 0.01

$c$  = taper on diameter according to S10.6.4.1, in [mm]

**S10**

(cont)

Notwithstanding the above, the push up length is not to be less than 2 mm.

Note: In case of hydraulic pressure connections the required push-up force  $P_e$ , in [N], for the cone may be determined by the following formula:

$$P_e = p_{req} d_m \pi \ell \left( \frac{c}{2} + 0.02 \right)$$

The value 0.02 is a reference for the friction coefficient using oil pressure. It varies and depends on the mechanical treatment and roughness of the details to be fixed. Where due to the fitting procedure a partial push-up effect caused by the rudder weight is given, this may be taken into account when fixing the required push-up length, subject to approval by the Society.

**S10.7 Pintles****7.1 Scantlings**

The pintle diameter, in mm, is not to be less than:

$$d_p = 0.35 \sqrt{B k_p}$$

where:

B = relevant bearing force, in N

$k_p$  = material factor for pintle as given in S10.1.3.5

**7.2 Couplings****7.2.1 Tapering**

Pintles are to have a conical attachment to the gudgeons with a taper on diameter not greater than:

1:8 - 1:12 for keyed and other manually assembled pintles applying locking by slugging nut,

1:12 - 1:20 on diameter for pintles mounted with oil injection and hydraulic nut.

**7.2.2 Push-up pressure for pintle bearings**

The required push-up pressure for pintle bearings, in N/mm<sup>2</sup>, is to be determined by the following formula:

$$p_{req} = 0.4 \frac{B_1 d_0}{d_m^2 \ell} \quad [\text{N/mm}^2]$$

where:

$B_1$  = Supporting force in the pintle bearing, in [N]

$d_0$  = Pintle diameter, in [mm], see Figure 5

## S10 (cont)

The push up length is to be calculated similarly as in S10.6.4.3, using required push-up pressure and properties for the pintle bearing.

~~7.2.3~~**7.3** The minimum dimensions of threads and nuts are to be determined according to ~~para~~ S10.6.3.3.

### ~~7.3~~**7.4** Pintle housing

The length of the pintle housing in the gudgeon is not to be less than the pintle diameter  $d_p D_p$ .  $D_p d_p$  is to be measured on the outside of liners.

The thickness of the pintle housing is not to be less than  $0.25 d_p D_p$ .

## S10.8 Rudder stock bearing, rudder shaft bearing and pintle bearing

### 8.1 Liners and bushes

#### 8.1.1 Rudder stock bearing

Liners and bushes are to be fitted in way of bearings. The minimum thickness of liners and bushes is to be equal to:

- $t_{min} = 8$  mm for metallic materials and synthetic material
- $t_{min} = 22$  mm for lignum material

#### 8.1.2 Pintle bearing

The thickness of any liner or bush, in mm, is neither to be less than:

$$t = 0.01\sqrt{B}$$

where:

$$B = \text{relevant bearing force, in [N]}$$

nor than the minimum thickness defined in S10.8.1.1.

### 8.2 Minimum bearing surface

An adequate lubrication is to be provided.

The bearing surface  $A_b$  (defined as the projected area: length x outer diameter of liner) is not to be less than:

$$A_b = P / q_a \text{ [mm}^2\text{]}$$

where:

$$P = \text{reaction force [N] in bearing as determined in S10.3.2;}$$

$$q_a = \text{allowable surface pressure according to the table below.}$$

## S10 (cont)

The maximum surface pressure  $q_a$  for the various combinations is to be taken as reported in Table 3 the table below. Higher values than given in the table may be taken in accordance with makers' specifications if they are verified by tests:

Bearing material	$q_a$ [N/mm <sup>2</sup> ]
lignum vitae	2.5
white metal, oil lubricated	4.5
synthetic material with hardness between 60 and 70 Shore D <sup>1)</sup>	5.5 <sup>2)</sup>
steel <sup>23)</sup> and bronze and hot-pressed bronze-graphite materials	7.0

**Table 3 Maximum surface pressure  $q_a$**

Notes:

- 1) Indentation hardness test at 23°C and with 50% moisture, are to be carried out according to a recognized standard. Synthetic bearing materials are to be of an approved type.
- 2) Surface pressures exceeding 5.5 N/mm<sup>2</sup> may be accepted in accordance with bearing manufacturer's specification and tests, but in no case more than 10 N/mm<sup>2</sup>.
- 3) Stainless and wear-resistant steel in an approved combination with stock liner.

### 8.3 Bearing Dimensions

The length/diameter ratio of the bearing surface is not to be greater than 1.2.

The bearing length  $L_p$  of the pintle is to be such that

$$D_p \leq L_p \leq 1.2 D_p$$

where:

$$D_p = \text{Actual pintle diameter measured on the outside of liners.}$$

### 8.4 Bearing clearances

With metal bearings, clearances should not be less than  $d_b / 1000 + 1.0$  [mm] on the diameter. If non-metallic bearing material is applied, the bearing clearance is to be specially determined considering the material's swelling and thermal expansion properties. This clearance is not to be taken less than 1.5 mm on bearing diameter unless a smaller clearance is supported by the manufacturer's recommendation and there is documented evidence of satisfactory service history with a reduced clearance.

## S10.9 Strength of sole pieces and of rudder horns

### 9.1 Sole piece

# S10

(cont)

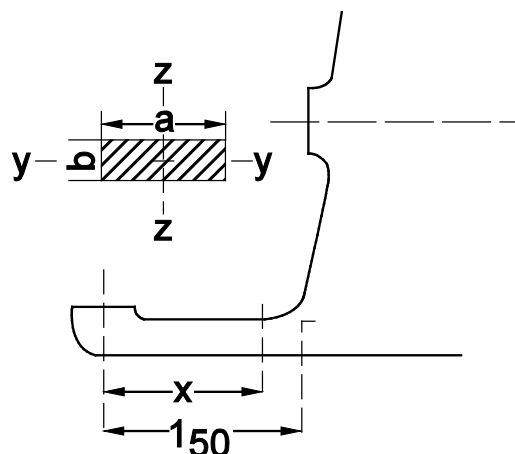

**Figure 7 Sole piece**

The section modulus around the vertical (z)-axis is not to be less than:

$$Z_z = M_b \underline{\underline{Kk}} / 80 \quad [\text{cm}^3]$$

The section modulus around the transverse (y)-axis is not to be less than:

$$Z_y = 0.5 Z_z$$

The sectional area is not to be less than:

$$A_s = B_1 \underline{\underline{Kk}} / 48 \quad [\text{mm}^2]$$

$\underline{\underline{Kk}}$  = material factor as given in S10.1.3.2 or S10.1.3.5 respectively.

### 9.1.1 Equivalent stress

At no section within the length  $\ell_{50}$  is the equivalent stress to exceed  $115 / \underline{\underline{Kk}} \text{ N/mm}^2$ . The equivalent stress is to be determined by the following formula:

$$\sigma_e = \sqrt{\sigma_b^2 + 3\tau^2} \quad [\text{N/mm}^2];$$

where:

$$\sigma_b = M_b / Z_z(x) \quad [\text{N/mm}^2];$$

$$\underline{\underline{\tau}} = B_1 / A_s \quad [\text{N/mm}^2];$$

$M_b$  = bending moment at the section considered [Nm];

$$M_b = B_1 x \quad [\text{Nm}];$$

$$M_{b\max} = B_1 \ell_{50} \quad [\text{Nm}];$$

$B_1$  = supporting force in the pintle bearing [N] (normally  $B_1 = C_R / 2$ ).

# S10

(cont)

$K_k$  = material factor as given in S10.1.3.2 or S10.1.3.5 respectively.

## 9.2 Rudder horn

When the connection between the rudder horn and the hull structure is designed as a curved transition into the hull plating, special consideration ~~should~~ is to be given to the effectiveness of the rudder horn plate in bending and to the stresses in the transverse web plates.

The bending moments and shear forces are to be determined by a direct calculation or in line with the guidelines given in Annex S10.5 and Annex S10.6 for semi spade rudder with one elastic support and semi spade rudder with 2-conjugate elastic support respectively.

The section modulus around the horizontal x-axis is not to be less than:

$$Z_x = M_b K_k / 67 \quad [\text{cm}^3].$$

$M_b$  = bending moment at the section considered [Nm];

The shear stress is not to be larger than:

$$\underline{\tau} = 48 / K_k \quad [\text{N/mm}^2].$$

$k$  = material factor as given in S10.1.3.2 or S10.1.3.5 respectively.

### 9.2.1 Equivalent stress

At no section within the ~~length~~ height of the rudder horn is the equivalent stress to exceed  $120 / k \text{ N/mm}^2$ . The equivalent stress is to be calculated by the following formula:

$$\sigma_e = \sqrt{\sigma_b^2 + 3(\tau^2 + \tau_T^2)} \quad [\text{N/mm}^2];$$

$$\sigma_b = M_b / Z_x \quad [\text{N/mm}^2];$$

$$\underline{\tau} = B_1 / A_h \quad [\text{N/mm}^2];$$

$B_1$  = supporting force in the pintle bearing [N];

$A_h$  = effective shear area of rudder horn in y-direction [ $\text{mm}^2$ ];

$$\underline{\tau}_T = M_T 10^3 / 2 A_T t_h \quad [\text{N/mm}^2];$$

$M_T$  = torsional moment [Nm];

$A_T$  = area in the horizontal section enclosed by the rudder horn [ $\text{mm}^2$ ];

$t_h$  = plate thickness of rudder horn [mm];

$k$  = material factor as given in S10.1.3.2 or S10.1.3.5 respectively.

### 9.2.2 Rudder horn plating

The thickness of the rudder horn side plating is not to be less than:

## S10 (cont)

$$t = 2.4\sqrt{Lk} \quad [\text{mm}]$$

where:

L = Rule length as defined in UR S2;

k = material factor as given in S10.1.3.2 or S10.1.3.5 respectively.

### 9.2.3 Welding and connection to hull structure

The rudder horn plating is to be effectively connected to the aft ship structure, e.g. by connecting the plating to side shell and transverse/ longitudinal girders, in order to achieve a proper transmission of forces, see Figure 8.

Brackets or stringer are to be fitted internally in horn, in line with outside shell plate, as shown in Figure 8.

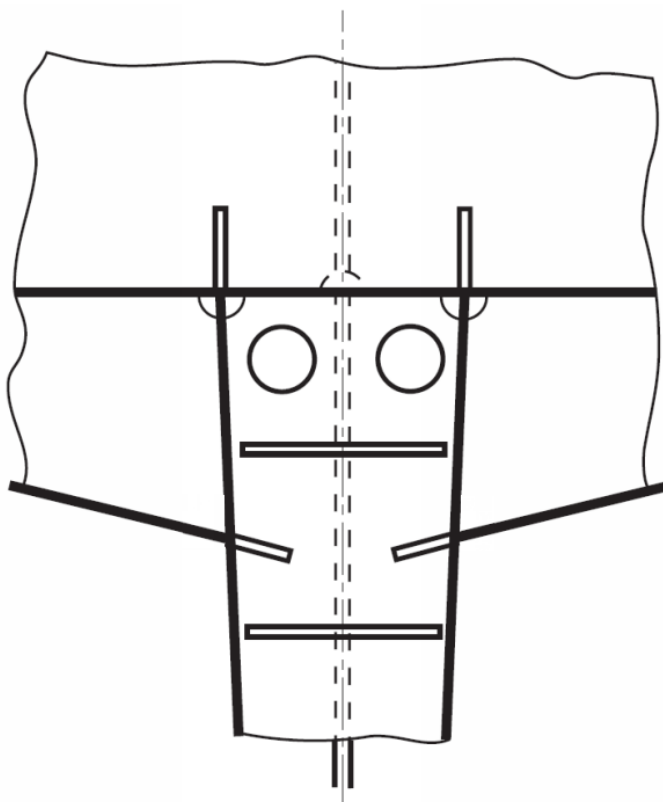

**Figure 8 Connection of rudder horn to aft ship structure**

Transverse webs of the rudder horn are to be led into the hull up to the next deck in a sufficient number.

Strengthened plate floors are to be fitted in line with the transverse webs in order to achieve a sufficient connection with the hull.

The centre line bulkhead (wash-bulkhead) in the after peak is to be connected to the rudder horn.



## S10 (cont)

Scallops are to be avoided in way of the connection between transverse webs and shell plating.

The weld at the connection between the rudder horn plating and the side shell is to be full penetration. The welding radius is to be as large as practicable and may be obtained by grinding.

### 9.3 Rudder trunk

#### 9.3.1 Materials, welding and connection to hull

This requirement applies to both trunk configurations (extending or not below stern frame).

The steel used for the rudder trunk is to be of weldable quality, with a carbon content not exceeding 0.23% on ladle analysis and a carbon equivalent  $C_{EQ}$  not exceeding 0.41.

Plating materials for rudder trunks are in general not to be of lower grades than corresponding to class II as defined in UR S6.

The weld at the connection between the rudder trunk and the shell or the bottom of the skeg is to be full penetration.

The fillet shoulder radius  $r$ , in mm (see Figure 9) is to be as large as practicable and to comply with the following formulae:

$$r = 60 \text{ [mm]} \quad \text{when } \sigma \geq 40 / k \text{ [N/mm}^2\text{]}$$

$$r = 0.1d_c, \text{ without being less than } 30 \text{ [mm]} \quad \text{when } \sigma < 40 / k \text{ [N/mm}^2\text{]}$$

where:

$d_c$  = rudder stock diameter axis defined in S10.4.2.

$\sigma$  = bending stress in the rudder trunk in N/mm<sup>2</sup>.

$k$  = material factor as given in S10.1.3.2 or S10.1.3.5 respectively.

The radius may be obtained by grinding. If disk grinding is carried out, score marks are to be avoided in the direction of the weld. The radius is to be checked with a template for accuracy. Four profiles at least are to be checked. A report is to be submitted to the Surveyor.

Rudder trunks comprising of materials other than steel are to be specially considered by the Society.

# S10

(cont)

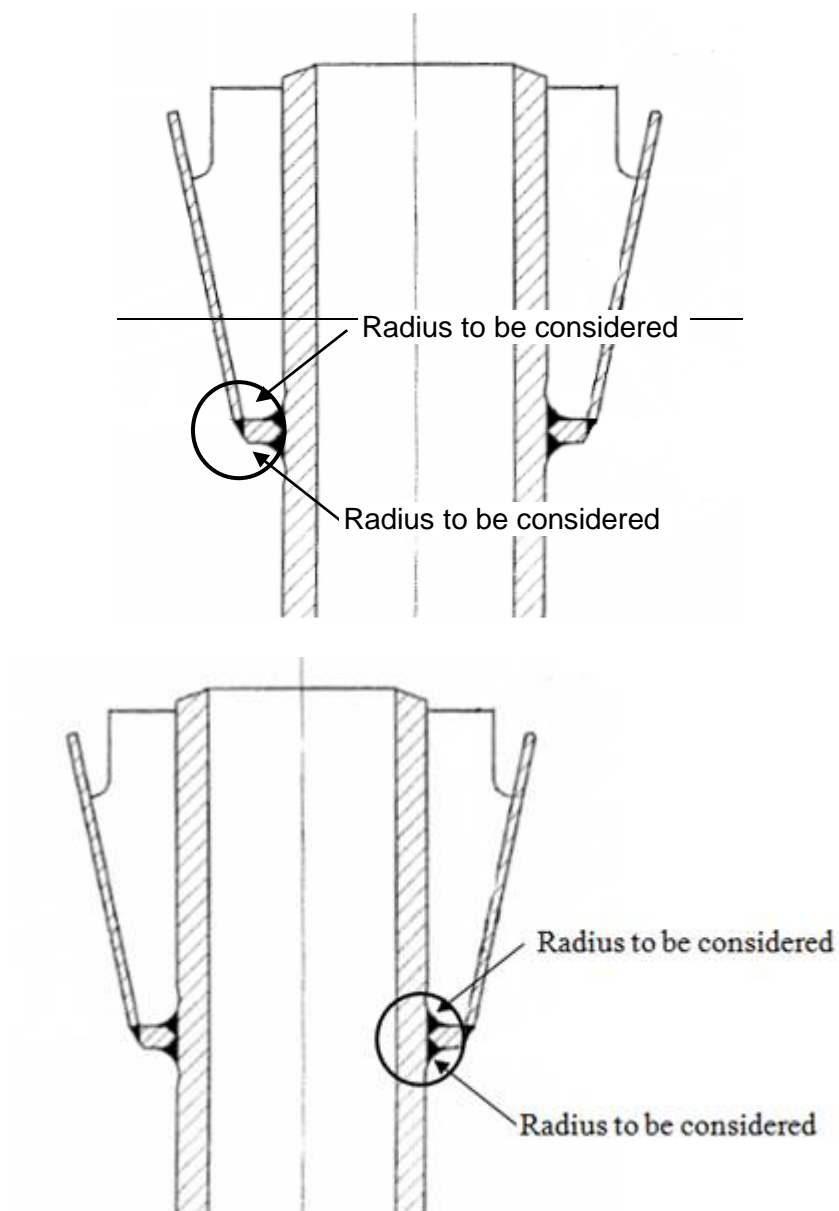

**Figure 9 Fillet shoulder radius**

## 9.3.2 Scantlings

Where the rudder stock is arranged in a trunk in such a way that the trunk is stressed by forces due to rudder action, the scantlings of the trunk are to be such that:

- the equivalent stress due to bending and shear does not exceed  $0.35 \sigma_F$ ,
- the bending stress on welded rudder trunk is to be in compliance with the following formula:  $\sigma \leq 80 / k$  [N/mm<sup>2</sup>]

with:

- $\sigma$  = bending stress in the rudder trunk, as defined in S10.9.3.1.
- $k$  = material factor for the rudder trunk as given in S10.1.3.2 or S10.1.3.5 respectively, not to be taken less than 0.7

**S10****(cont)** $\sigma_F$  = yield stress (N/mm<sup>2</sup>) of the material used

For calculation of bending stress, the span to be considered is the distance between the mid-height of the lower rudder stock bearing and the point where the trunk is clamped into the shell or the bottom of the skeg.

## **S10**   **Annex** (cont)

# **Guidelines for calculation of bending moment and shear force distribution**

### **AnnexS10.1   General**

The evaluation of bending moments, shear forces and support forces for the system rudder–rudder stock may be carried out for some basic rudder types as outlined in AnnexS10.2-AnnexS10.6.

# S10

(cont)

## AnnexS10.2 Spade rudder

### Data for the analysis

$l_{10} - l_{30}$  = Lengths of the individual girders of the system in [m]

$I_{10} - I_{30}$  = Moments of inertia of these girders in [cm<sup>4</sup>]

Load of rudder body:

$$P_R = C_R / (l_{10} 10^3) \quad [\text{kN/m}]$$

### Moments and forces

The moments and forces may be determined by the following formulae:

$$M_b = C_R (l_{20} + (l_{10} (2 C_1 + C_2) / 3 (C_1 + C_2))) \quad [\text{Nm}]$$

$$B_3 = M_b / l_{30} \quad [\text{N}]$$

$$B_2 = C_R + B_3 \quad [\text{N}]$$

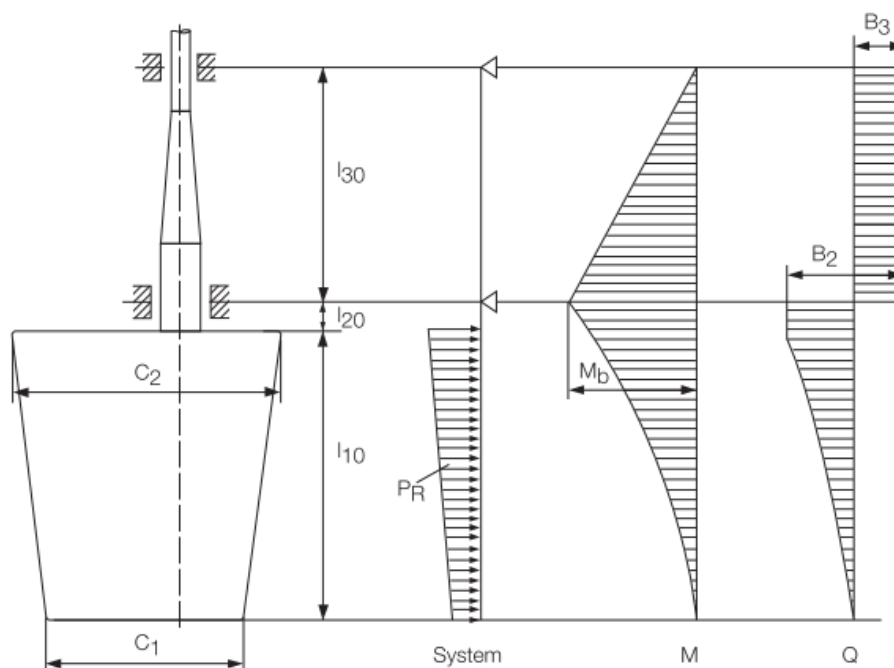

Figure A 1

# S10

(cont)

## AnnexS10.3 Spade rudder with trunk

### Data for the analysis

$l_{10} - l_{30}$  = Lengths of the individual girders of the system in [m]

$I_{10} - I_{30}$  = Moments of inertia of these girders in [cm<sup>4</sup>]

Load of rudder body:

$$P_R = C_R / ((l_{10} + l_{20})10^3) \quad [\text{kN/m}]$$

### Moments and forces

For spade rudders with rudders trunks the moments, in Nm, and forces, in N, may be determined by the following formulae:

$M_R$  is the greatest of the following values:

$$M_R = C_{R2} (l_{10}l_{40} - CG_{2Z})$$

$$M_R = C_{R1} (CG_{1Z} - l_{10}l_{40})$$

where:

$C_{R1}$  : Rudder force over the rudder blade area  $A_1$

$C_{R2}$  : Rudder force over the rudder blade area  $A_2$

$CG_{1Z}$  : Vertical position of the centre of gravity of the rudder blade area  $A_1$

$CG_{2Z}$  : Vertical position of the centre of gravity of the rudder blade area  $A_2$

$$M_B = C_{R2} (l_{40}l_{10} - CG_{2Z})$$

$$B_3 = (M_B + M_{CR1}) / (l_{20}l_{20} + l_{30}l_{30})$$

$$B_2 = C_R + B_3$$

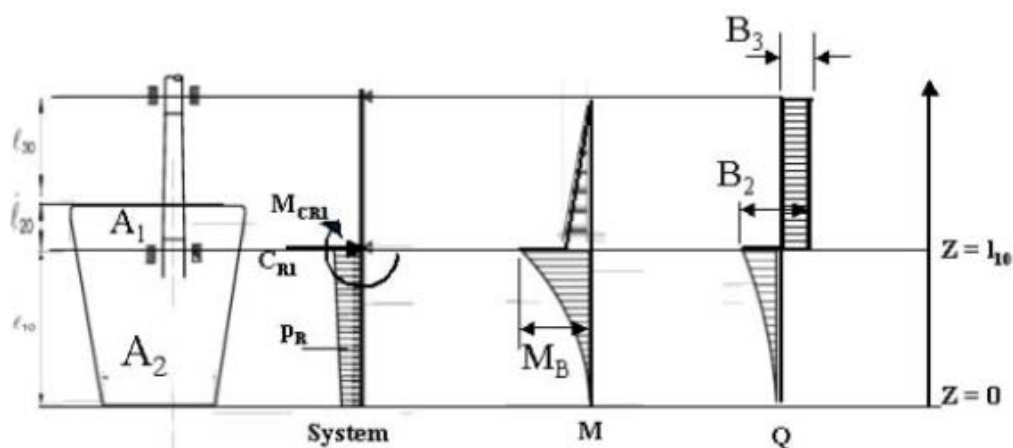

Figure A 2

**S10****AnnexS10.4 Rudder supported by sole piece**

(cont)

**Data for the analysis**

$l_{10} - l_{50}$  = Lengths of the individual girders of the system in [m]

$I_{10} - I_{50}$  = Moments of inertia of these girders in [cm<sup>4</sup>]

For rudders supported by a sole piece the length  $l_{20}$  is the distance between lower edge of rudder body and centre of sole piece and  $I_{20}$  the moment of inertia of the pintle in the sole piece.

$I_{50}$  = moment of inertia of sole piece around the z-axis [cm<sup>4</sup>];

$l_{50}$  = effective length of sole piece in [m];

Load of rudder body:

$P_R = C_R / (l_{10} 10^3)$  [kN/m]

$Z$  = spring constant of support in the sole piece

$Z = 6.18 \times I_{50} / l_{50}^3$  [kN/m]

**Moments and forces**

Moments and shear forces are indicated in Figure A 3

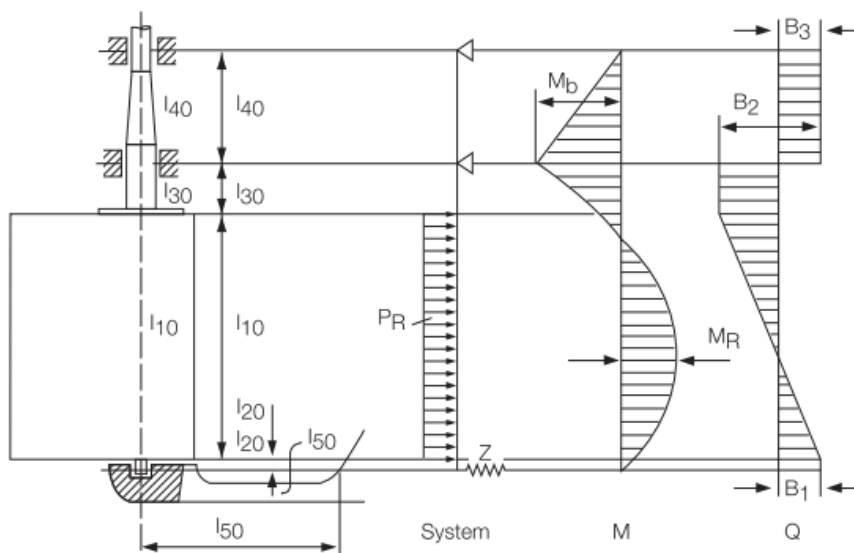

**Figure A 3**

**S10****AnnexS10.5 Semi spade rudder with one elastic support**

(cont)

**Data for the analysis**

$l_{10} - l_{50}$  = Lengths of the individual girders of the system in [m];

$I_{10} - I_{50}$  = Moments of inertia of these girders in [cm<sup>4</sup>];

Z = spring constant of support in the rudder horn;

Z =  $1 / (f_b + f_t)$  [kN/m] for the support in the rudder horn (Figure A 4);

$f_b$  = unit displacement of rudder horn in [m] due to a unit force of 1 kN acting in the centre of support;

$f_b$  =  $1.3 d^3 / (6.18 I_n)$  [m/kN] (guidance value);

$I_n$  = moment of inertia of rudder horn around the x-axis in [cm<sup>4</sup>] (see also Figure A 4);

$f_t$  = unit displacement due to torsion;

$f_t$  =  $de^2 \sum u_i / t_i / (3.14 \times 10^8 F_T^2)$  [m/kN];

$F_T$  = mean sectional area of rudder horn in [m<sup>2</sup>];

$u_i$  = breadth in [mm] of the individual plates forming the mean horn sectional area;

$t_i$  = thickness within the individual breadth  $u_i$  in [mm];

d = Height of the rudder horn, in m, defined in Figure A 4. This value is measured downwards from the upper rudder horn end, at the point of curvature transition, to the mid-line of the lower rudder horn pintle;

e = distance as defined in Figure A 5

Load of rudder body:

$P_{R10} = C_{R2} / (l_{10} \times 10^3)$  [kN/m];

$P_{R20} = C_{R1} / (l_{4020} \times 10^3)$  [kN/m];

for  $C_R, C_{R1}, C_{R2}$ , see S10.2.

**Moments and forces**

Moments and shear forces are indicated in Figure A 4.

**Rudder horn**

The loads on the rudder horn are as follows:

$M_b$  = bending moment =  $B_1 z$  [Nm],  $M_{bmax} = B_1 d$  [Nm]



**S10**  
(cont)

$q = \text{shear force} = B_1 \text{ [N]}$

$M_T(z) = \text{torsional moment} = B_1 e(z) \text{ [Nm]}$

An estimate for  $B_1$  is:

$$B_1 = C_R b / (l_{20} + l_{30}) \quad \text{[N]}$$

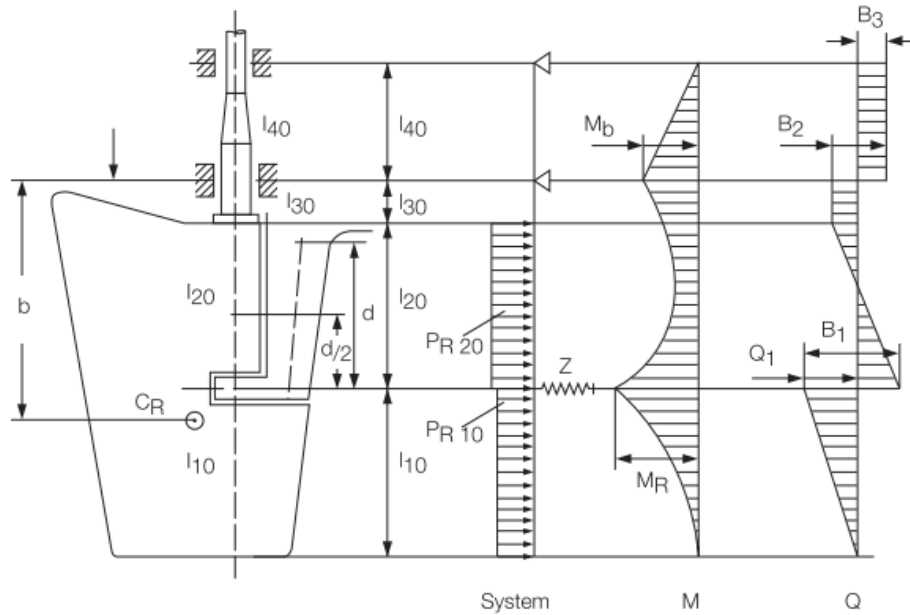

Figure A 4

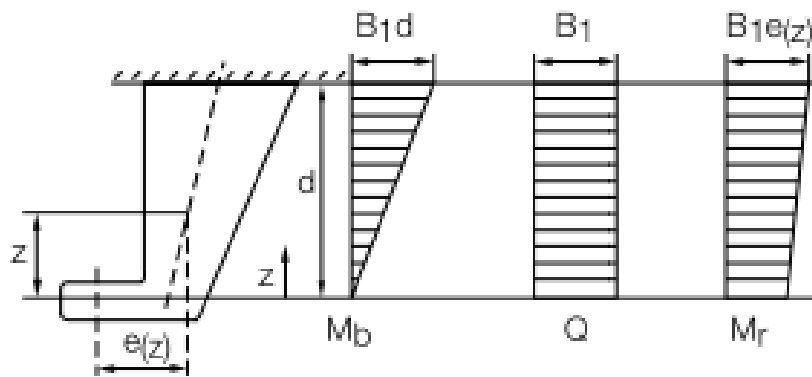

Figure A 5

# S10

(cont)

## AnnexS10.6 Semi spade rudder with 2-conjugate elastic support

### Data for the analysis

$K_{11}$ ,  $K_{22}$ ,  $K_{12}$  : Rudder horn compliance constants calculated for rudder horn with 2-conjugate elastic supports (Figure A 6). The 2-conjugate elastic supports are defined in terms of horizontal displacements,  $y_i$ , by the following equations:

at the lower rudder horn bearing:

$$y_1 = -K_{12} B_2 - K_{22} B_1$$

at the upper rudder horn bearing:

$$y_2 = -K_{11} B_2 - K_{12} B_1$$

where:

$y_1$ ,  $y_2$  : Horizontal displacements, in m, at the lower and upper rudder horn bearings, respectively.

$B_1$ ,  $B_2$  : Horizontal support forces, in kN, at the lower and upper rudder horn bearings, respectively.

$K_{11}$ ,  $K_{22}$ ,  $K_{12}$  : Obtained, in m/kN, from the following formulae:

$$K_{11} = 1.3 \frac{\lambda^3}{3EJ_{1h}} + \frac{e^2 \lambda}{GJ_{th}}$$

$$K_{22} = 1.3 \left[ \frac{\lambda^3}{3EJ_{1h}} + \frac{\lambda^2(d - \lambda)}{2EJ_{1h}} \right] + \frac{e^2 \lambda}{GJ_{th}}$$

$$K_{12} = 1.3 \left[ \frac{\lambda^3}{3EJ_{1h}} + \frac{\lambda^2(d - \lambda)}{EJ_{1h}} + \frac{\lambda(d - \lambda)^2}{EJ_{1h}} + \frac{(d - \lambda)^3}{3EJ_{2h}} \right] + \frac{e^2 d}{GJ_{th}}$$

$d$  : Height of the rudder horn, in m, defined in Figure A 6. This value is measured downwards from the upper rudder horn end, at the point of curvature transition, to the mid-line of the lower rudder horn pintle.

$\lambda$  : Length, in m, as defined in Figure A 6. This length is measured downwards from the upper rudder horn end, at the point of curvature transition, to the mid-line of the upper rudder horn bearing. For  $\lambda = 0$ , the above formulae converge to those of spring constant  $Z$  for a rudder horn with 1-elastic support, and assuming a hollow cross section for this part.

$e$  : Rudder-horn torsion lever, in m, as defined in Figure A 6 (value taken at  $z = d/2$ ).

$J_{1h}$  : Moment of inertia of rudder horn about the x axis, in  $m^4$ , for the region above the upper rudder horn bearing. Note that  $J_{1h}$  is an average value over the length  $\lambda$  (see Figure A 6).

## S10 (cont)

$J_{2h}$  : Moment of inertia of rudder horn about the x axis, in  $m^4$ , for the region between the upper and lower rudder horn bearings. Note that  $J_{2h}$  is an average value over the length  $d - \lambda$  (see Figure A 6).

$J_{th}$  : Torsional stiffness factor of the rudder horn, in  $m^4$ .

For any thin wall closed section:

$$J_{th} = \frac{4F_T^2}{\sum_i \frac{u_i}{t_i}}$$

$F_T$  : Mean of areas enclosed by outer and inner boundaries of the thin walled section of rudder horn, in  $m^2$ .

$u_i$  : Length, in mm, of the individual plates forming the mean horn sectional area.

$t_i$  : Thickness, in mm, of the individual plates mentioned above.

Note that the  $J_{th}$  value is taken as an average value, valid over the rudder horn height.

Load of rudder body:

$$P_{R10} = C_{R2} / (\ell_{10} \times 10^3) \text{ [kN/m];}$$

$$P_{R20} = C_{R1} / (\ell_{4020} \times 10^3) \text{ [kN/m];}$$

for  $C_R$ ,  $C_{R1}$ ,  $C_{R2}$ , see S10.2.2

### Moments and forces

Moments and shear forces are indicated in Figure A 6

#### Rudder horn bending moment

The bending moment acting on the generic section of the rudder horn is to be obtained, in Nm, from the following formulae:

- between the lower and upper supports provided by the rudder horn:

$$M_H = F_{A1} Z$$

- above the rudder horn upper-support:

$$M_H = F_{A1} Z + F_{A2} (Z - d_{lu})$$

where:

$F_{A1}$  : Support force at the rudder horn lower-support, in N, to be obtained according to Figure A 6, and taken equal to  $B_1$ .

$F_{A2}$  : Support force at the rudder horn upper-support, in N, to be obtained according to Figure A 6, and taken equal to  $B_2$ .

## S10 (cont)

$z$  : Distance, in m, defined in Figure A 7, to be taken less than the distance  $d$ , in m, defined in the same figure.

$d_{lu}$  : Distance, in m, between the rudder-horn lower and upper bearings (according to Figure A 6,  $d_{lu} = d - \lambda$ ).

### Rudder horn shear force

The shear force  $Q_H$  acting on the generic section of the rudder horn is to be obtained, in N, from the following formulae:

- between the lower and upper rudder horn bearings:

$$Q_H = F_{A1}$$

- above the rudder horn upper-bearing:

$$Q_H = F_{A1} + F_{A2}$$

where:

$F_{A1}$ ,  $F_{A2}$  : Support forces, in N.

The torque acting on the generic section of the rudder horn is to be obtained, in Nm, from the following formulae:

- between the lower and upper rudder horn bearings:

$$M_T = F_{A1} e_{(z)}$$

- above the rudder horn upper-bearing:

$$M_T = F_{A1} e_{(z)} + F_{A2} e_{(z)}$$

where:

$F_{A1}$ ,  $F_{A2}$  : Support forces, in N

$e_{(z)}$  : Torsion lever, in m, defined in Figure A 7.

### Rudder horn shear stress calculation

For a generic section of the rudder horn, located between its lower and upper bearings, the following stresses are to be calculated:

$\tau_S$ : Shear stress, in  $N/mm^2$ , to be obtained from the following formula:

$$\tau_S = \frac{F_{A1}}{A_H}$$

$\tau_T$  : Torsional stress, in  $N/mm^2$ , to be obtained for hollow rudder horn from the following formula:

# S10

(cont)

$$\tau_T = \frac{M_T 10^3}{2F_T t_H}$$

For solid rudder horn,  $\tau_T$  is to be considered by the Society on a case by case basis.

For a generic section of the rudder horn, located in the region above its upper bearing, the following stresses are to be calculated:

$\tau_S$ : Shear stress, in N/mm<sup>2</sup>, to be obtained from the following formula:

$$\tau_S = \frac{F_{A1} + F_{A2}}{A_H}$$

$\tau_T$ : Torsional stress, in N/mm<sup>2</sup>, to be obtained for hollow rudder horn from the following formula:

$$\tau_T = \frac{M_T 10^3}{2F_T t_H}$$

For solid rudder horn,  $\tau_T$  is to be considered by the Society on a case by case basis where:

$F_{A1}$ ,  $F_{A2}$ : Support forces, in N;

$A_H$ : Effective shear sectional area of the rudder horn, in mm<sup>2</sup>, in y-direction;

$M_T$ : Torque, in Nm;

$F_T$ : Mean of areas enclosed by outer and inner boundaries of the thin walled section of rudder horn, in m<sup>2</sup>;

$t_H$ : Plate thickness of rudder horn, in mm. For a given cross section of the rudder horn, the maximum value of  $\tau_T$  is obtained at the minimum value of  $t_H$ .

## Rudder horn bending stress calculation

For the generic section of the rudder horn within the length  $d$ , the following stresses are to be calculated:

$\sigma_B$ : Bending stress, in N/mm<sup>2</sup>, to be obtained from the following formula:

$$\sigma_B = \frac{M_H}{W_X}$$

where:

$M_H$ : Bending moment at the section considered, in Nm.

$W_X$ : Section modulus, in cm<sup>3</sup>, around the X-axis (see Figure A 7).

**S10**  
(cont)

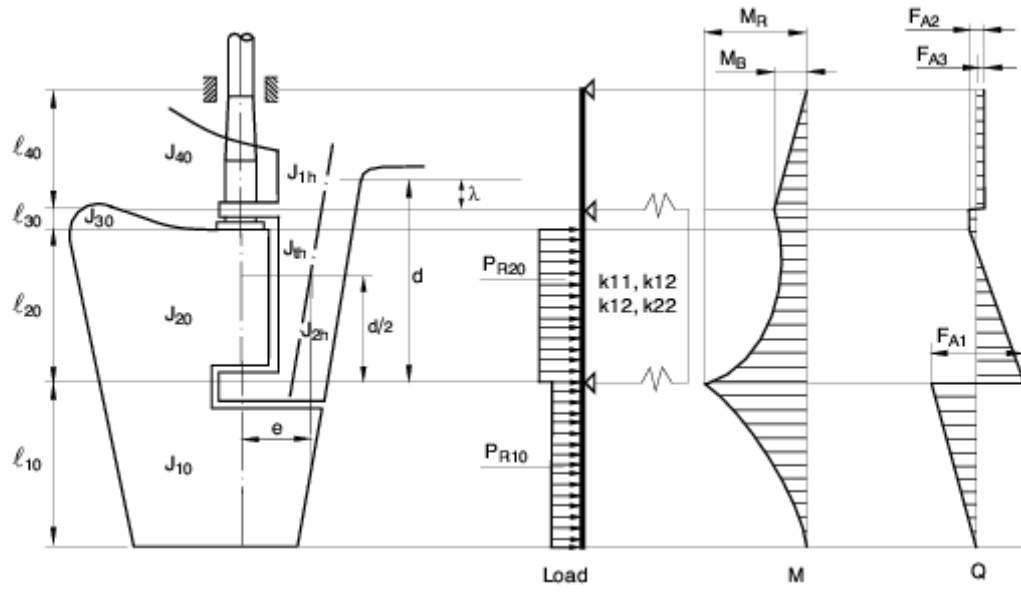

Figure A 6

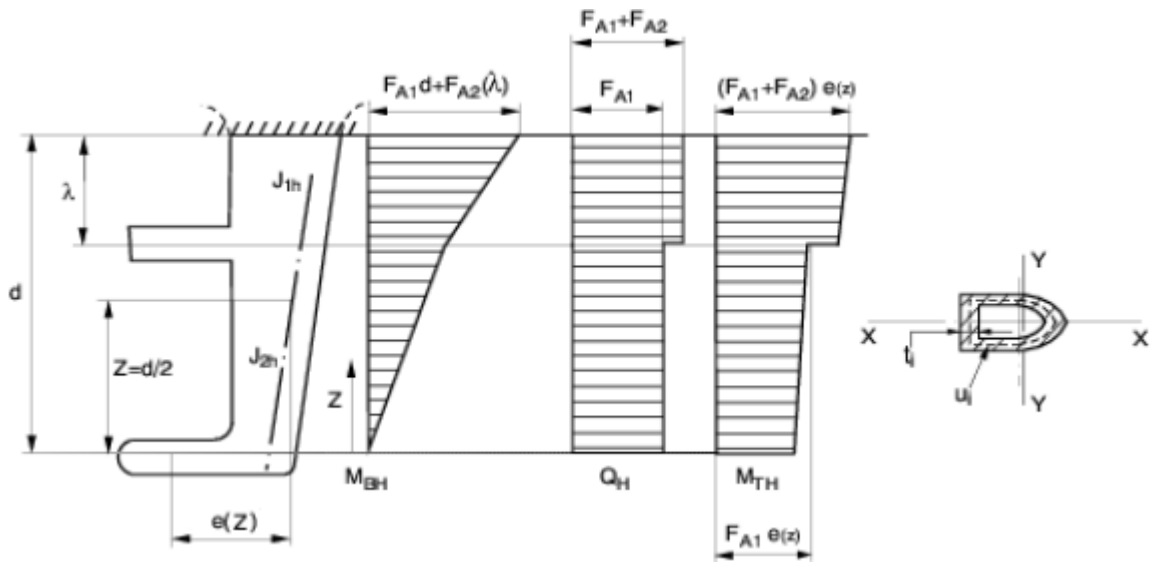

Figure A 7

End of Document