

TÜRK LOYDU



DESIGN, CONSTRUCTION AND TESTING OF PUMPS 2013

This latest edition incorporates all rule changes. The latest revisions are shown with a vertical line. The section title is framed if the section is revised completely. Changes after the publication of the rule are written in red colour.

Unless otherwise specified, these Rules apply to ships for which the date of contract for construction as defined in IACS PR No.29 is on or after 4th of February 20.

"General Terms and Conditions" of the respective latest edition will be applicable (see Rules for Classification and Surveys).

If there is a difference between the rules in English and in Turkish, the rule in English is to be considered as valid. This publication is available in print and electronic pdf version.

Once downloaded, this document will become UNCONTROLLED. Please check www.turkloydu.org for the amended and valid version.

All rights are reserved by Türk Loydu, and content may not be reproduced, disseminated, published, or transferred in any form or by any means, except with the prior written permission of TL.

TÜRK LOYDU

Head Office Postane Mah. Tersaneler Cad. No:26 Tuzla 34944 İSTANBUL / TÜRKİYE
Tel : (90-216) 581 37 00
Fax : (90-216) 581 38 00
E-mail : info@turkloydu.org
<http://www.turkloydu.org>

Regional Offices

Ankara Eskişehir Yolu Mustafa Kemal Mah. 2159. Sokak No : 6/4 Çankaya - ANKARA / TÜRKİYE
Tel : (90-312) 219 56 34 - 219 68 25
Fax : (90-312) 219 69 72
E-mail : ankara@turkloydu.org

İzmir Atatürk Cad. No :378 K.4 D.402 Kavalalılar Apt. 35220 Alsancak - İZMİR / TÜRKİYE
Tel : (90-232) 464 29 88
Fax : (90-232) 464 87 51
E-mail : izmir@turkloydu.org

Adana Çınarlı Mah. Atatürk Cad. Aziz Naci İş Merkezi No:5 K.1 D.2 Seyhan - ADANA / TÜRKİYE
Tel : (90- 322) 363 30 12
Fax : (90- 322) 363 30 19
E-mail : adana@turkloydu.org

Marmaris Atatürk Cad. 99 Sok. No:1 Ketenbaş Apt. Kat:4 Daire 6 Marmaris - MUĞLA / TÜRKİYE
Tel : (90- 252) 412 46 55
Fax : (90- 252) 412 46 54
E-mail : marmaris@turkloydu.org

List of Rules

Part Chapter Title

A	1	Rules for Classification of Steel Ships – Hull
A	2	Rules for Classification of Steel Ships – Material
A	3	Rules for Classification of Steel Ships – Welding
B	4	Rules for Classification of Steel Ships – Machinery
B	5	Rules for Classification of Steel Ships – Electrical Installation
C	7	High Speed Crafts
C	8	Chemical Tankers
C	9	Construction and Classification of Yachts
C	10	Liquefied Gas Tankers
C	11	Fire Fighting Ships
C	12	Oil Recovery Vessels
C	13	Escort Tugs
C	14	Fishing Vessels
C	15	Refrigerating Installations
C	16	Pipe Laying Vessels
C	17	Pusher, Pusher/Barge Units
C	18	Drilling Vessels
C	19	Inland Waterway Vessels
C	20	Cable Laying Vessels
C	21	Navigation Bridge Visibility, Bridge Arrangement and Equipment Rules
C	22	Dynamic Positioning Systems
C	23	Redundant Propulsion and Steering Systems
C	24	Chemical Recovery Vessels
C	25	Machinery Condition Monitoring
C	26	Use of Fuel Cell Systems on Board of Ships and Boats
C	27	Construction of Wooden Passenger Vessels Less than 24 m. in Length
C	28	Ventilation
C	30	Wooden Fishing Vessels
C	32	Rigging for Large Sailing Ships
C	33	Construction of Polar Class Ships
D	50	Regulation for Lifting Appliances
D	51	Stowage and Lashing of Containers
D	52	Diving Systems
D	53	Submersibles
D	54	Underwater Equipment
D	55	Construction, Repair and Testing of Freight Containers
D	58	Ocean Towing
D	59	Offshore Technology - Classification, Certification and Surveys
D	60	Offshore Technology - Mobile Offshore Units
D	61	Offshore Technology - Fixed Offshore Installations
D	62	Offshore Technology - Structural Design
D	63	Offshore Technology Machinery Installations
D	64	Offshore Technology – Electrical Installations
D	70	Multiple Point Mooring Systems
D	76	Environmental Service System
D	77	Certification of Floating Oil Booms
E	101	Naval Ship Technology, Classification and Surveys
E	102	Naval Ship Technology, Hull Structures and Ship Equipment
E	103	Metallic Materials, Special Materials for Naval Ships
E	104	Naval Ship Technology, Propulsion Plants
E	105	Naval Ship Technology, Electrical Installations
E	106	Naval Ship Technology, Automation
E	107	Naval Ship Technology, Ship Operation Installations and Auxiliary Systems
E	111	Naval Ship Technology, Submarines
E	112	Naval Ship Technology, Remotely Operated Underwater Vehicles
E	113	Naval Ship Technology, Air Independent Power Systems for Underwater Use
F	200	Certification of Wind Turbines
F	201	Certification of Offshore Wind Turbines
F	202	Certification of Condition Monitoring Systems for Wind Turbines

DESIGN, CONSTRUCTION AND TESTING OF PUMPS

	Page
A. General	1
B. Design and Construction Principles	1
C. Testing	3
Annex A Illustration Of Principles Of Pumps	

A. General

1. Scope

The following Rules apply to the design, construction and testing of pumps for the handling of liquids.

The application of these Rules covers pumps whose capacity in accordance with the TL Rules, Chapter 4 – Machinery, Section 16, D. have to be verified in the manufacturer's works as well as pumps and motors of hydraulically operated systems in accordance with Chapter 4 – Machinery, Section 10.

These Rules may be similarly applied to other pumps as appropriate.

2. Definition

For the purpose of these Rules, liquid pumps include:

- Rotodynamic pumps
- Side channel pumps
- Rotary and oscillating positive displacement pumps
- Liquid ejectors

For pumps of other designs, the requirements are to be agreed on a case to case basis.

3. Documents to be Submitted

In the case of pumps for handling liquid gases, dangerous chemicals and liquid foodstuffs, sectional

drawings together with details relating to the proposed materials and operating conditions are to be submitted in triplicate to the TL Head Office for approval.

Approval of drawings is not normally required for other pumps.

In individual cases and depending on the design and application the Society does, however, reserve the right to call for the documentation necessary to an assessment of the pump in question.

B. Design and Construction Principles

1. Materials

1.1 Approved materials

The materials of the pump components shall be suitable for the proposed applications. They are to be selected with due regard to the operating conditions and the nature of the liquid to be handled. The Rules for Materials issued by TL are to be observed. These Rules apply analogously to pressurized parts attached to the pumps.

Where the working temperature (t_{per}) of the liquid to be pumped is ≤ -10 °C, the choice of materials is subject to the requirements of TL Rules, Chapter 2 –Materials.

Where dangerous chemicals are to be pumped, evidence is to be supplied to TL attesting the suitability of the materials used.

1.2 Requirements on material manufacturers

Casings for pumps intended to be used for piping systems of pipe class (**See Chapter 4- Machinery, Section 16, Table 16.1**) I and II shall be manufactured by TL approved manufacturers. For the use in pipe class III piping systems an approval according to other recognized standards may be accepted.

1.3 Limits on the application of materials for pump casings

1.3.1 Cast iron with lamellar graphite (at least EN-GJL-200)

max. allowable working temperature $t_{per} \leq 200 \text{ }^\circ\text{C}$

max. allowable working pressure $P_{e,per} \leq 16 \text{ bar}$

Limitations:

- For boiler water $P_{e,per} \leq 10 \text{ bar}$
- For liquid fuels, lubricating oil, $t_{per} \leq 60 \text{ }^\circ\text{C}$ and for flammable hydraulic $P_{e,per} \leq 7 \text{ bar fluid}$

Not permitted:

- For casings of circulating pumps for heat-transfer oil
- For casings of pumps for handling of dangerous chemicals

1.3.2 Nodular cast iron (Elongation A5 at least 12 %)

max. allowable working temperature $t_{per} \leq 300 \text{ }^\circ\text{C}$ for nodular cast iron in normal quality

max. allowable working temperature $t_{per} \leq 350 \text{ }^\circ\text{C}$ for nodular cast iron in special quality according to TL Rules Chapter 2 – Materials, Section 7, acceptable for casings of circulating pumps for heat-transfer oil

1.3.3 Steel and cast steel for general applications

max. allowable working temperature $t_{per} \leq 300 \text{ }^\circ\text{C}$

1.3.4 Cast copper alloys

max. allowable working temperature $t_{per} \leq 200 \text{ }^\circ\text{C}$ for

copper and aluminium brass,

max. allowable working temperature $t_{per} \leq 300 \text{ }^\circ\text{C}$ for copper nickel alloys

1.3.5 Aluminium casting alloys

max. allowable working temperature $t_{per} \leq 200 \text{ }^\circ\text{C}$ with the approval of the TL.

1.3.6 Plastics

The use of plastics requires the approval of TL in the individual case of application.

1.4 Casing repairs

Casting defects in pump casings may be repaired only by recognized methods. The TL surveyor is to be notified prior to the execution of the repair.

2. Protection Against Excessive Pressure

2.1 Rotodynamic pumps must be so designed that they can be operated for a short time without damage even with the discharge line closed.

2.2 Positive displacement pumps must be protected against excessive pressure increases in the pump casing by fitting relief valves which cannot be adjusted to the closed position.

2.3 Pumps which do not clearly conform to one of these two designs must comply with requirement 2.1 or 2.2.

3. Rated Output of Prime Mover

3.1 General requirements

The rated output of the prime mover is to be determined in such a way as to ensure the reliable operation of the pump under all anticipated operating conditions.

It is required to be compatible with the mode of operation, the characteristic curve of the pump and with the properties of the liquid to be pumped.

3.2 Prime movers for rotodynamic pumps

By the way of a guide, the following values can, for example, normally be regarded as adequate in the case

of rotodynamic pumps intended for operation in closed piping systems, e.g. fresh cooling water systems, brine systems, thermal oil systems:

Rated power of pump P_N [kW]	Rated power of prime mover P_M [kW]
up to 10	$> 1,2 P_N$
up to 50	$1,2 - 1,1 P_N$
over 50	$1,1 P_N$

Prime mover for pumps intended for operation in open piping systems, e.g. fire and emergency fire systems, ballast and bilge systems shall be rated for the entire capacity range of the pump. Unrestricted operation is to be ensured including direct (non throttled) discharge over board at maximum inlet head (max. draught). The rated output of the prime mover shall include a reserve power of not less than 10 %.

3.3 Prime movers for rotodynamic pumps

Prime movers of positive displacement pumps shall be rated for short circuit operation at maximum viscosity, i.e. the total flow is returned to the suction side via the relief valve.

4. Branches, Connections

As far as possible, inlet and outlet branches shall be designed for the same rated pressure.

Pipe connections are to be executed in such a manner that no unpermissible forces and moments are exerted on the pump.

5. Circulating Pumps for Heat-Transfer Oil

The shaft sealing of circulating pumps for heat transfer oil must be so designed that oil leakage cannot occur in an unacceptable manner and unacceptable leakage rate.

For shaft seals and/or bearings fitted with a cooling system the circulation flow is to be monitored.

6. Emergency Fire Pumps

Emergency fire pumps shall be of self-priming type or be equipped with additional suction aid.

For emergency fire pumps installed above the water line in light condition of the ship, the NPSH (1) of the pump (NPSHreq) should be about 1 m lower than the NPSH value of the plant (NPSHa). Details for determining NPSHa are given in Fig. 1.

C. Testing

1. Testing of Materials

1.1 The following are subject to material testing and certification in accordance with TL Rules:

- Casings of boiler water circulating pumps with a permitted working pressure of $P_{e,per} \geq 10$ bar
- Casings of pumps for handling liquids with a working temperature of $t_{per} \leq -10$ °C
- Casings of pumps for handling dangerous chemicals.

1.2 For all other pumps, the casing materials may be attested by a test report 2.2 according to EN 10204. The same procedure is also to be applied to the materials used for rotating components.

1.3 Type and scope of non-destructive material tests are to be agreed between the pump manufacturer and the foundry appropriate to the application requirements, for example, in case of pumps handling chemicals or liquid gases.

2. Pressure Testing

2.1 All pump components exposed to internal pressure (casing, cover, seal plate) are to be subjected to a hydrostatic pressure test.

The following test pressure p_p at least is to be applied:

(1) *NPSH = Net Positive Suction Head, see also EURO PUMP: NPSH on Rotodynamic Pumps European Committee of Pump Manufacturers or ISO 9906*

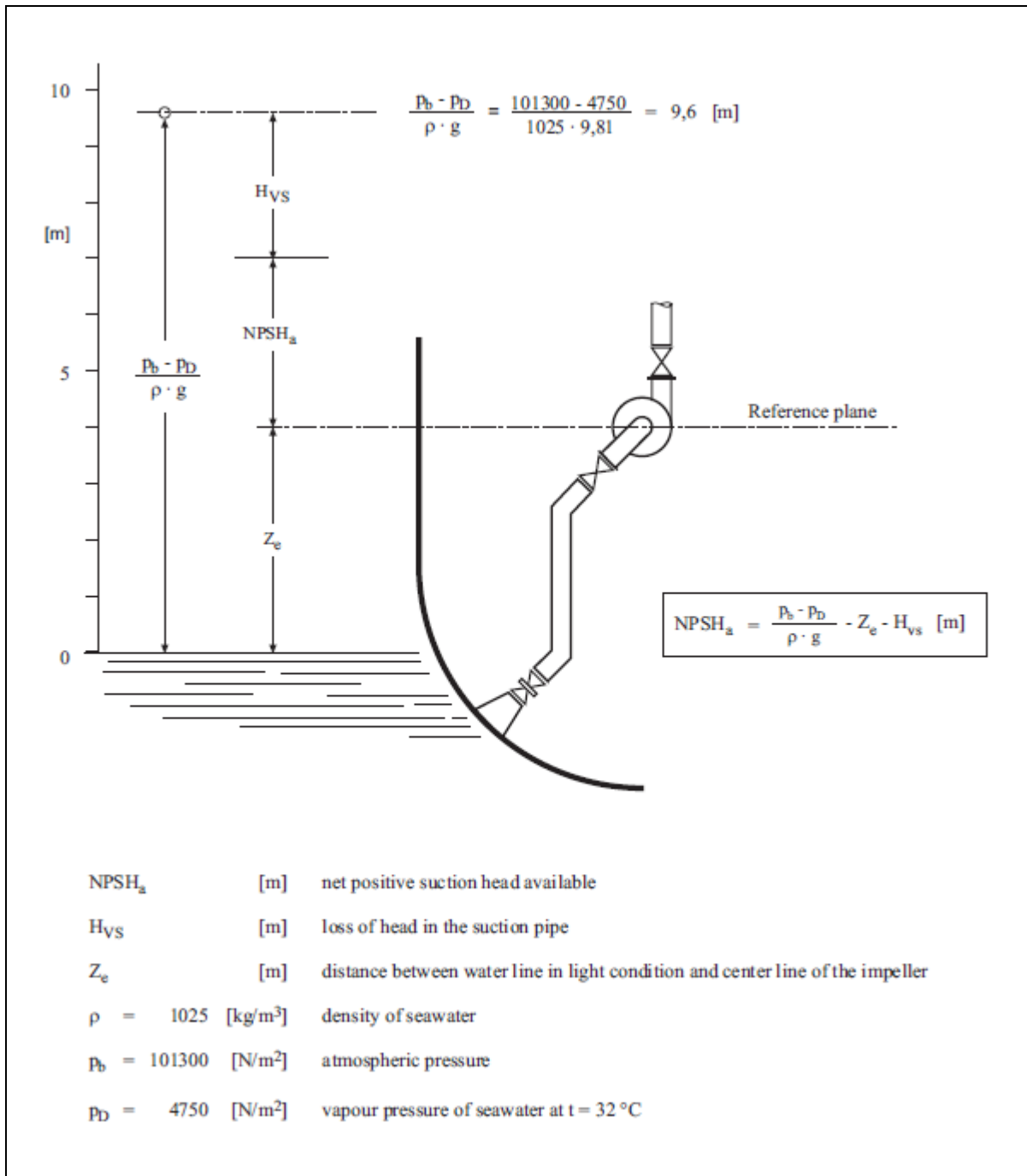


Fig. 1 Calculation of NPSHa for emergency fire pumps which are installed above the water line in light condition

$P_p = 1,5 P_{e,per}$ where $P_{e,per} \leq 200$ bar subject to a minimum of $P_p = 4$ bar

$P_p = P_{e,per} + 100$ bar where $P_{e,per} > 200$ bar

$P_{e,per}$ = maximum allowable working pressure

2.1.1 In the case of rotodynamic pumps, the maximum allowable working pressure $P_{e,per}$ is equal to the sum of the pressure in the suction branch and the

maximum pressure difference according to the pump characteristic.

2.1.2 In case of positive displacement pumps, the maximum allowable working pressure $P_{e,per}$ is equal to the pressure which occurs on the discharge side when the total flow is returned to the suction side via the relief valve. The maximum pressure at the suction branch shall be considered.

2.2 For the purpose of hydrostatic pressure testing, pump casings shall not be painted on their internal or external surfaces.

3. Performance Testing

3.1 The following pumps are subject to final inspection and to hydraulic performance testing in the manufacturer's works under the supervision of a TL Surveyor:

- Bilge pumps / bilge ejectors
- Ballast pumps
- Seawater cooling pumps
- Fresh water cooling pumps
- Cooling pumps for fuel injection valves
- Fire pumps
- Emergency fire pumps
- Condensate pumps
- Boiler feed water pumps
- Boiler water circulating pumps
- Lubricating oil pumps
- Fuel oil booster and transfer pumps
- Circulating pumps for heat-transfer oil
- Brine pumps
- Refrigerant circulating pumps
- Cargo pumps
- Hydraulic pumps for controllable pitch propellers

Other hydraulic pumps / hydraulic motors, see TL Rules Chapter 4 - Machinery, Section 10.

3.2 The following contractually agreed operating data are to be verified during the performance test:

Volume rate of flow (2)	Q [m ³ /h]
Delivery head	H [m]
Pump power input	P [kW]
Speed of rotation	n [min ⁻¹]

3.3 As a standard procedure the hydraulic performance test shall be performed on manufacturer's test bench.

The procedure followed shall be based on recognized national or international Standards and Regulations, such as:

- DIN EN ISO 9906 – Rotodynamic pumps – Hydraulic performance acceptance test grade 2,
- VDMA 24 284 – Testing of positive displacement pumps – General regulations for testing.

If the contract provides for a performance test in accordance with one of the aforementioned standards or a comparable regulation the pump manufacturer is bound to hold the said standard available for consultation during the performance test.

3.4 If the performance test is conducted without the corresponding prime mover but with a test bench motor, deviations from the nominal speed of rotation n_N may result which can be tolerated within specific limits. In case of rotodynamic pumps, the speed of rotation during testing shall be in line with ISO 9906.

Accordingly, the speed of rotation during testing shall be within the range 50 % and 120 % of the specified speed.

(2) *The volume rate of flow is defined as the usable volume rate which is delivered by the pump through its outlet cross-section (pressure socket).*

In order to translate the performance data Q, H and P measured at test speed n to the corresponding values for the specified speed n_N , the following equations may be applied:

$$Q_N = Q \left(\frac{n_N}{n} \right) \quad H_N = H \left(\frac{n_N}{n} \right)^2 \quad P_N = P \left(\frac{n_N}{n} \right)^3$$

3.5 For positive displacement pumps, the permissible deviations call for special agreement depending on the design involved.

3.6 Conversion of the measured power input P to the nominal power input P_N is also required where the power input is measured with a liquid which differs as regards density and/or viscosity from the liquid specified in the contract **(3)**

3.7 Where the contract calls for verification of the NPSH value, an approximation formula is to be agreed between customer and supplier to enable the conversion to be made if the test speed differs from the nominal speed.

3.8 Where pumps subject to mandatory testing are hydraulically driven, the corresponding hydraulic motors and hydraulic pumps are to undergo a performance test, unless the pump is performance-tested in conjunction with the entire unit.

4. Other Tests

4.1 On positive displacement pumps the setting and correct dimensioning of the relief valve is to be checked. Generally, the set pressure, the opening pressure and the reseating pressure shall be measured and documented. Where a positive displacement pump is supplied without a relief valve, this point is to be noted in the Test Certificate.

(3) *The effect of viscosity on the characteristic of pumps is shown in Figure 2.*

4.2 With self-priming rotodynamic pumps as well as for rotodynamic pumps with attached or built in suction aid, the functioning of the air intake stage is to be included within the scope of performance test.

4.3 During the performance test, the pump is to be checked for smooth running **(4)** and bearing temperature.

4.4 Where the performance test is carried out on the entire unit comprising the pump, coupling, prime mover and common base plate, the alignment of the unit is to be checked. The fact that the test has been performed on the entire unit is to be noted in the Test Certificate.

4.5 In case of performance testing of bilge ejectors the pressures shall be within $\pm 3\%$ of the nominal data. The resulting flow at the suction side may not deviate by more than -5% . Higher volume rate of flows are permitted.

5. Test Documents

5.1 The documents required for the various tests shall be supplied by the pump manufacturer to the Surveyor in good time and at the latest at the time of carrying out the tests.

5.2 A TL Test Certificate is to be issued showing the results of the tests. Where the extent of the tests goes beyond that specified by TL, the TL Test Certificate may be supplemented by the pump manufacturer's own test report.

(4) *The assessment may be based on VDI Regulation 2056 "Criteria for the assessment of mechanical vibration in machines" or on a comparable standard.*

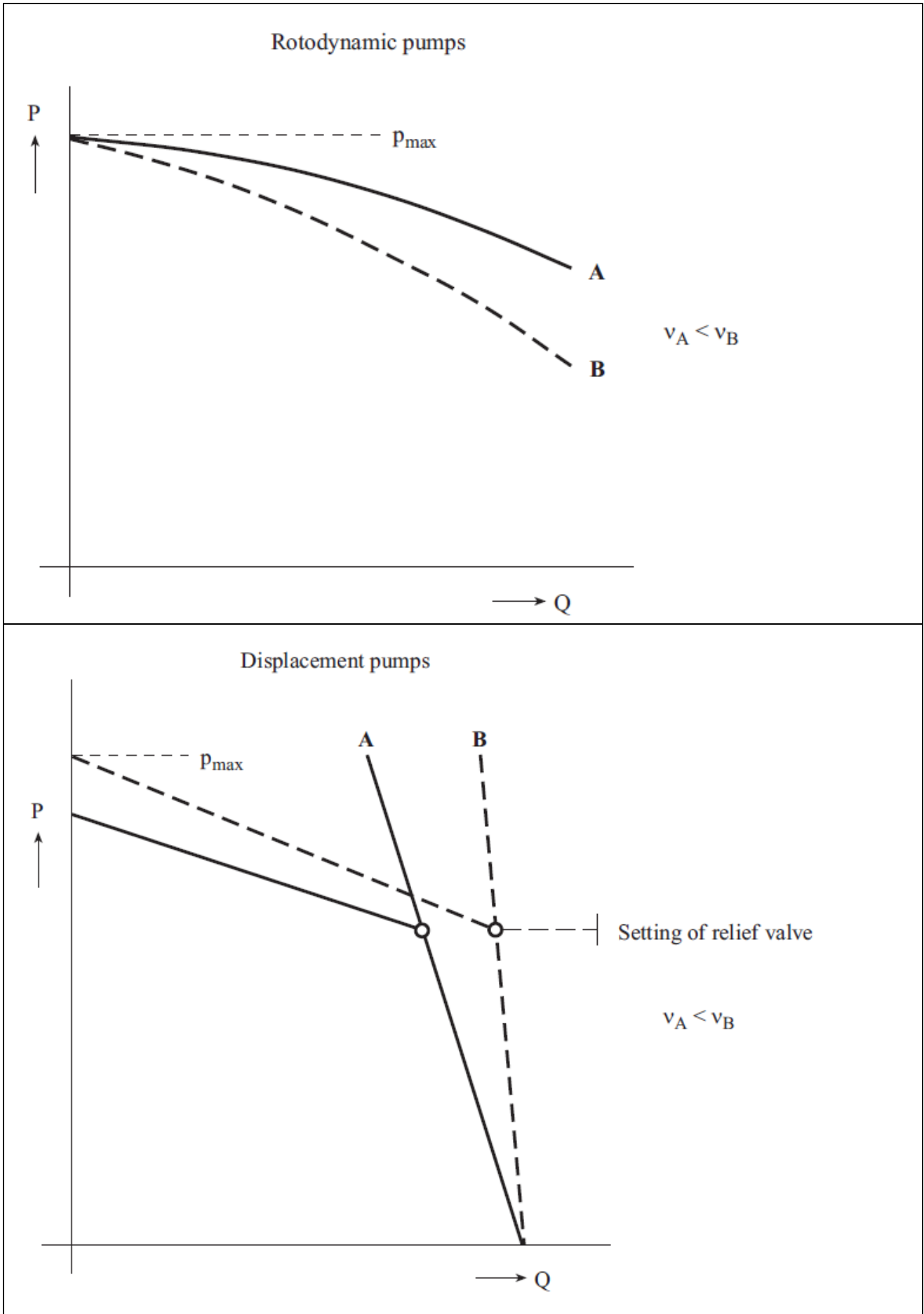


Fig. 2 Effect of viscosity v on pump characteristic

ANNEX A
ILLUSTRATION OF PRINCIPLES OF PUMPS

Note:

The following illustrations of the principles of pumps together with the appropriate terminology have been taken from volume 1 of the EUROPUMP Technical Dictionary with the agreement of the European Committee of Pump

Manufacturers. In the context of the present Regulations, it is hoped that this information complied by the European pump industry will contribute to the clear identification of pump types.

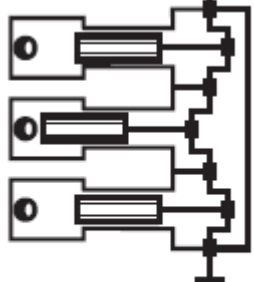
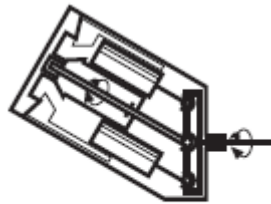
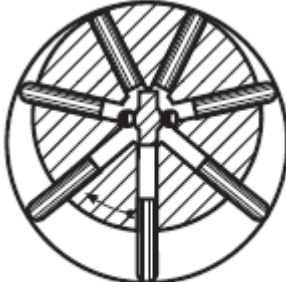


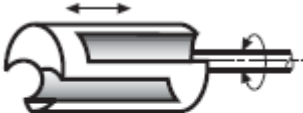
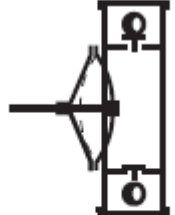
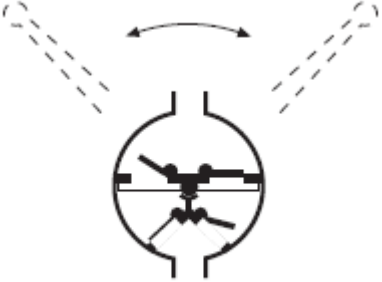
 <p>In line piston pump</p>	 <p>Axial piston pump</p>
 <p>Radial piston pump</p>	 <p>Ram pump</p>
 <p>Bucket pump (double acting)</p>	 <p>Rocking pintle piston pump</p>
 <p>Diaphragm pump</p>	 <p>Double acting semi rotary pump</p>

Fig. 3.1 Illustrations of the principles of reciprocating pumps

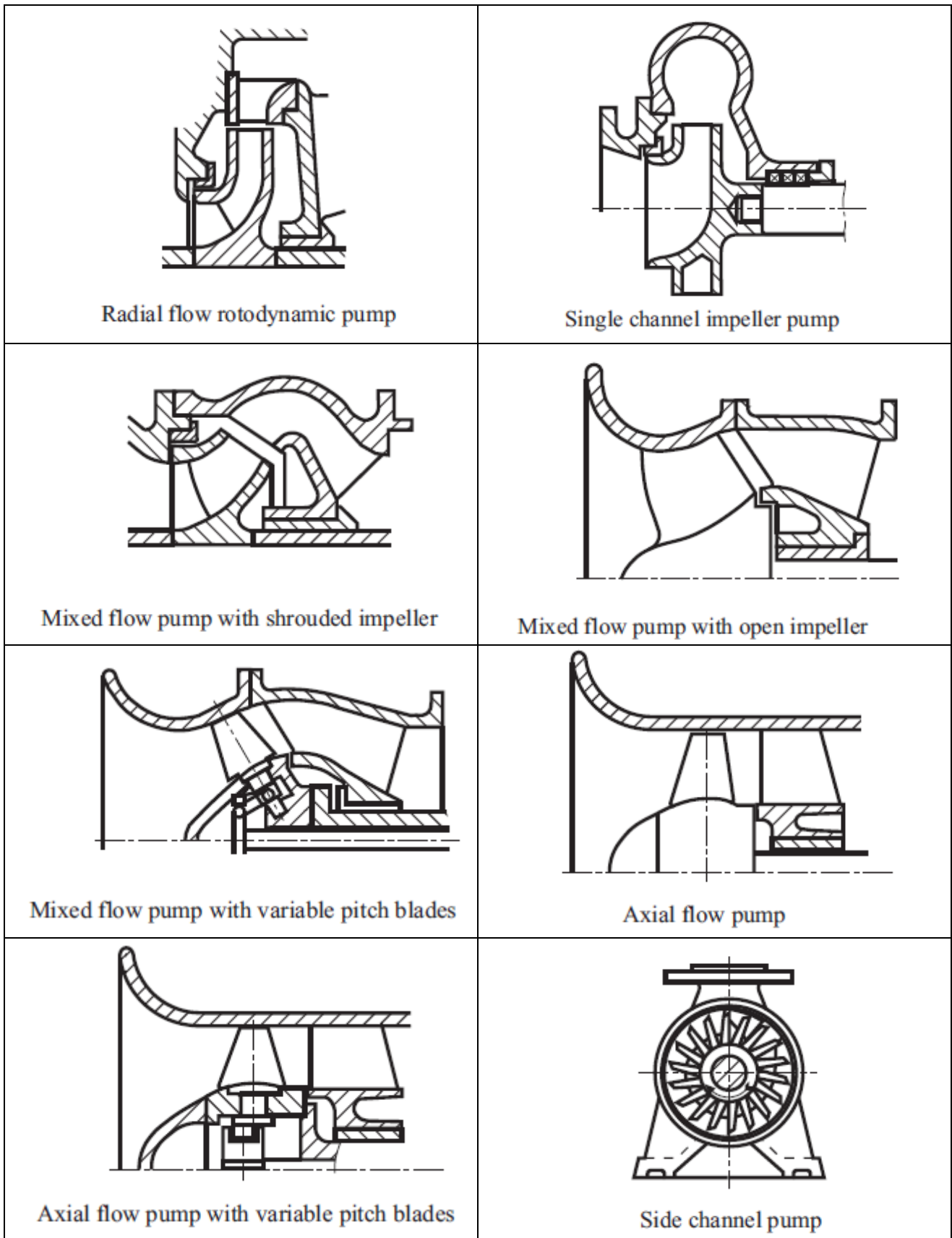


Fig. 3.2 Illustrations of the principles of rotodynamic pumps and side channel pump

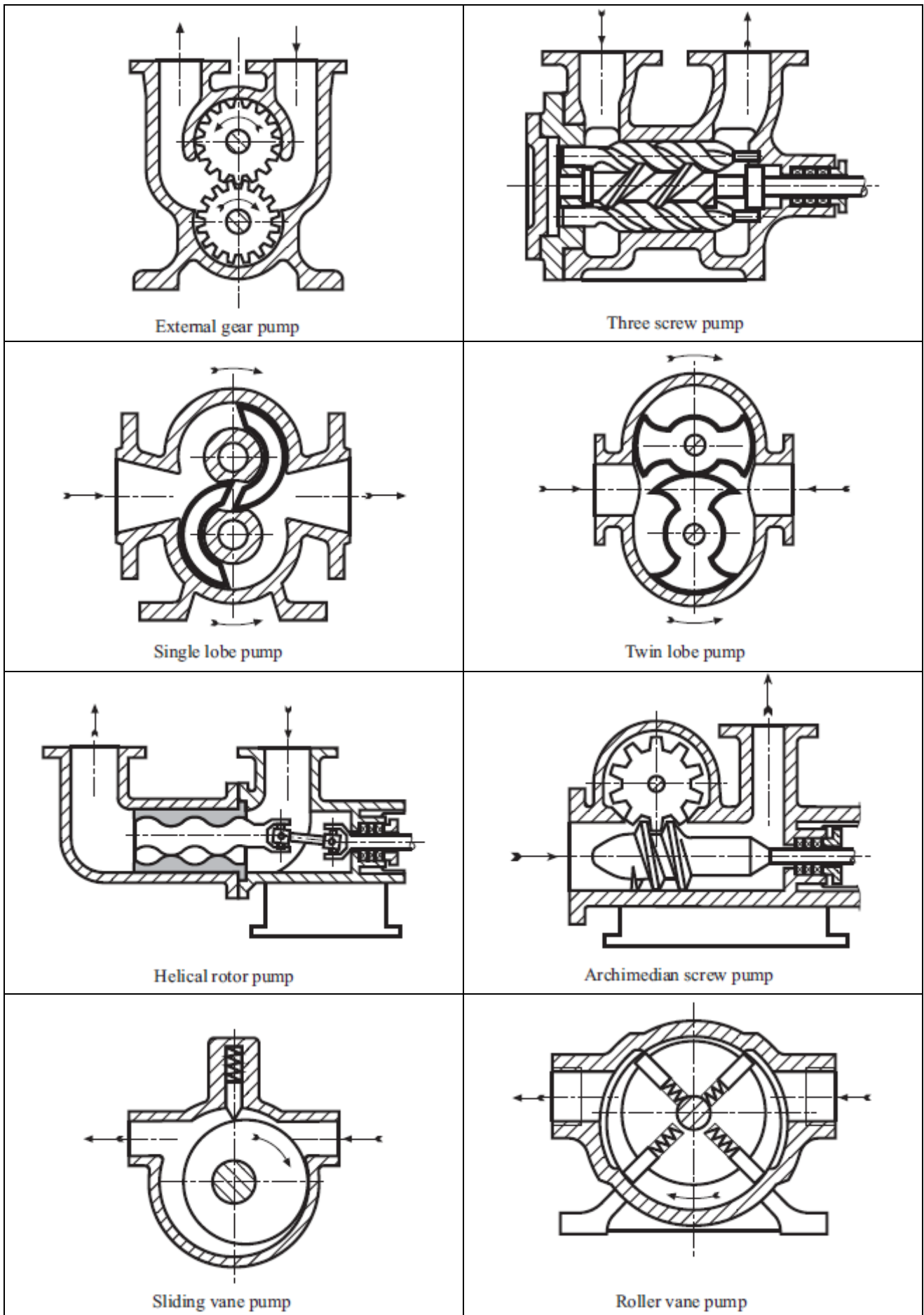


Fig. 3.3 Illustrations of principles of positive-rotary pumps

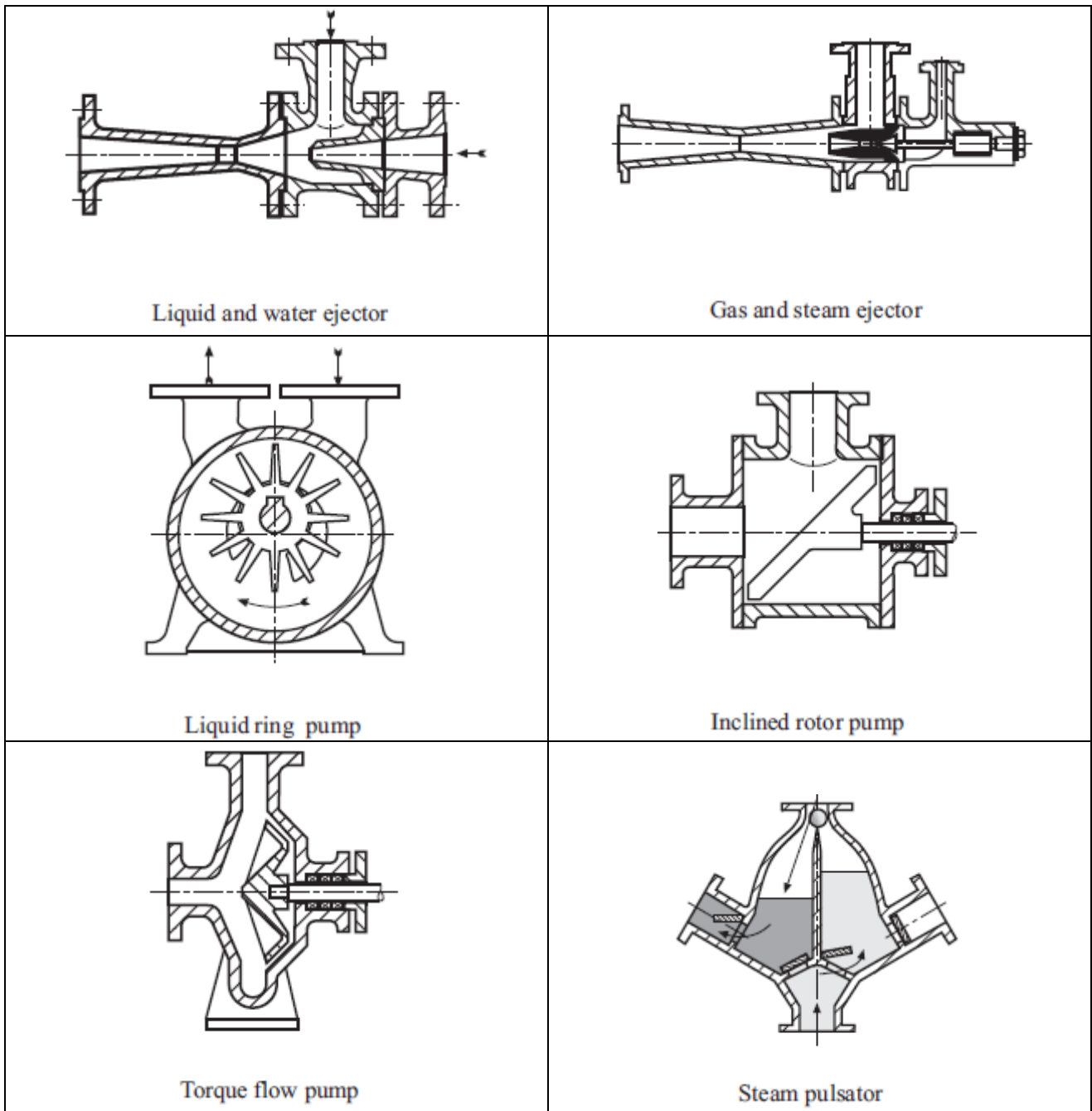


Fig. 3.4 Illustrations of the principles of other pumps